

Research on Statistical Characteristics of Partial Discharge Ultrasonic Signals in Switchgear

Tao Zhao^{1,a}, Chenhao Jia^{1,b,*}

¹North China Electric Power University (Baoding), Baoding, China

^aT.Zhao@ncepu.edu.cn, ^bhbdlncepu@163.com

*Corresponding author

Abstract: Switchgear plays a vital role in the power system and is an essential part of ensuring the safe and stable operation of the power system. In this paper, a test platform for partial discharge of switchgear is built on the laboratory site. The creeping discharge model used is the creeping discharge of insulators. At the same time, the ultrasonic signal is collected when partial discharge occurs in the switchgear. According to the data obtained by the platform, using the two characteristic parameters of shape and scale, analyze and discuss the ultrasonic partial discharge of the switchgear based on the threshold value, and give the threshold value suggestion of the switchgear in the actual operating state. The recommended values provide relevant suggestions for power grid operation and maintenance, and have certain guiding significance.

Keywords: Switchgear, Partial Discharge, Ultrasonic Signal, Weibull Distribution

1. Introduction

Switchgear plays a vital role in the power system and is an important part of ensuring the safe and stable operation of the power system. In recent years, accidents such as burnout and explosion of switchgear occur frequently, which seriously threaten the personal safety of staff and pose challenges to the stable operation of the power system. During operation, there will be various problems in the switchgear [1-2], among which the damage to the instrumentation accounts for the highest proportion, followed by partial discharge. When the switchgear works for a long time under the conditions of high voltage, high temperature, high humidity, strong magnetism, and high current, the insulation damage such as temperature overrun and condensation, insulation aging, insulation breakdown, etc. will occur. This situation is usually caused by partial discharge. In foreign power grids [3], insulation faults and mechanical faults occupy the highest position in the occurrence rate of switchgear faults. Insulation faults are mainly caused by partial discharge. If they are allowed to develop, it will lead to more serious faults in the switchgear, which will lead to the destruction of the safe and stable operation of the power system, endangering personal safety and the national economy. Therefore, it is very necessary and significant to monitor the partial discharge phenomenon of the switch cabinet and perform statistical analysis on the partial discharge signal.

Ultrasonic partial discharge detection method is also a non-invasive detection method used earlier [2-4]. It uses the ultrasonic wave generated by partial discharge and the signal intensity of ultrasonic partial discharge to determine the type of discharge. At present, the statistical analysis of the discharge signal is a very hot topic. Literature [5] reveals that the partial discharge signal of the transformer follows the Weibull statistical law, and literature [6] also reveals that the partial discharge of the GIS also obeys the Weibull distribution law. The characteristics of the literature [7] use Weibull to study the partial discharge problem of the cable. In addition to domestic research, literature [8] provides relevant statistical information in accordance with the IEEE 2004 statistical standard, and literature [9] studies the pulse height distribution of partial discharges identified by five-parameter Weibull processing. Based on the above research content and related conditions, for similar switchgear partial discharge signals [10-11], the Weibull distribution can be followed for judgment and analysis.

The relevant theoretical research on partial discharge and detection of switchgear has been relatively mature [12-14], but for the statistical analysis of partial discharge signals, domestic and foreign research mainly focuses on transformers, GIS, and cables. Because there are few failure samples in the field, the relative research is rare. In this paper, a switchgear partial discharge platform is built on the laboratory site, and the insulator creeping discharge model is used to collect ultrasonic

signals when partial discharge occurs in the switchgear. According to the two characteristic parameters of shape and scale, the ultrasonic data obtained from the partial discharge of the switchgear is analyzed and discussed based on the threshold value, and the threshold value suggestion of the switchgear in the actual operating state is given, so that the operation of the switchgear in the distribution network and power enterprises can be improved. Status has better monitoring and protection.

2. Switchgear partial discharge experimental platform

In order to simulate the working environment of high-voltage switchgear under actual working conditions, this paper builds a partial discharge experimental platform for high-voltage switchgear to simulate the partial discharge that occurs in high-voltage switchgear under actual operating conditions, and uses ultrasonic sensors to collect corresponding signals. The platform is mainly composed of voltage regulator, power frequency non-partial discharge test transformer, coupling capacitor and voltage divider, pulse current detection coil, oscilloscope, protection resistor, high-voltage switch cabinet, analog partial discharge model and signal acquisition device.

2.1 The construction of the experimental platform

The switchgear of the experimental platform selected in this paper is a laboratory 10kV switchgear, and the actual discharge model is placed in it. The step-up transformer is controlled by the output of the voltage regulator to boost the range of 0.4-22kV, and the current limiting resistor uses a 50M Ω protection water resistance. A voltage is applied across the test model and the ultrasonic sensor is set on the surface of the switchgear shell. The ultrasonic sensor on the switch cabinet is connected to the oscilloscope. When the voltage is applied, the voltage gradually increases. When partial discharge occurs, the ultrasonic sensor will collect the partial discharge signal and transmit the signal to the digital storage oscilloscope. Figure 1 below is the laboratory 10kV switchgear; Figure 2 is the partial discharge model of the insulator creeping discharge.



Figure 1: 10kV switchgear for experiment

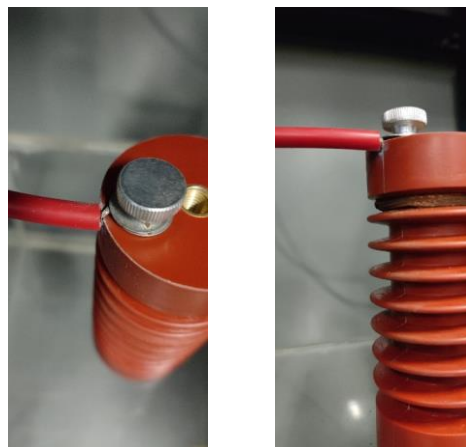

Figure 2: Creeping discharge model

2.2 Switchgear partial discharge experiment scheme

The insulator creeping discharge model is put into the switchgear and the experiment is pressurized. The specific experimental steps are as follows:

(1) According to the wiring schematic diagram, as shown in Figure 3 below, build the experimental platform, check the grounding wire before each experiment starts, and perform the discharge operation after the experiment is over.

(2) Start the power supply, adjust the applied voltage value within a certain range, record the voltage value of each boost and the corresponding partial discharge waveform. When partial discharge occurs, a digital storage oscilloscope is used to collect the ultrasonic sensor and record each rise. The magnitude of each partial discharge signal pressed corresponds to the magnitude of the voltage.

(3) Record the PD ultrasound data for ten seconds at each voltage level. Fig. 4 is the waveform diagram of ultrasound when there is discharge.

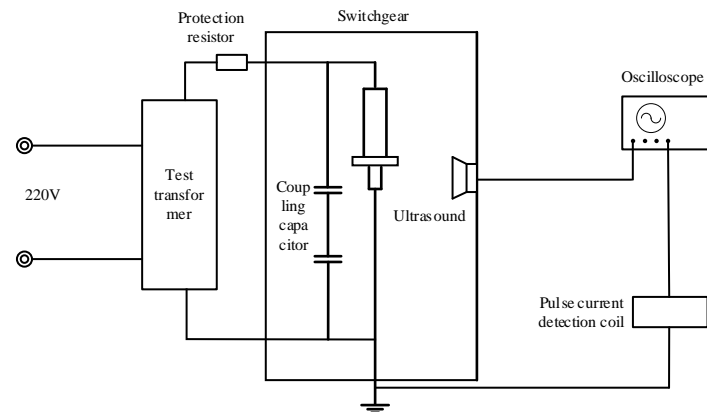

Figure 3: Wiring schematic

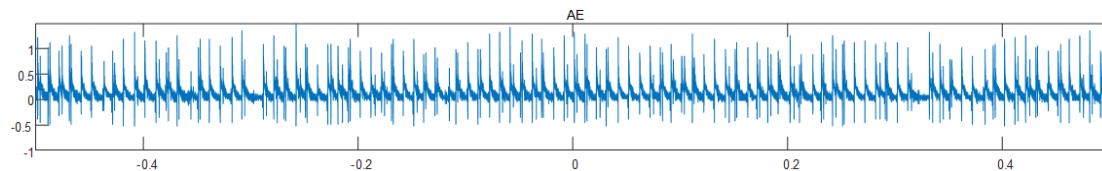

Figure 4: Ultrasonic graph

3. Data sample acquisition

In the experiment of partial discharge of switchgear, the laboratory adopts ultrasonic method to detect partial discharge. The experimental data records the waveform voltage value, and then extracts the peak value and converts it into the dB value common in the statistical research of partial discharge signal.

3.1 Processing of raw data

In terms of conversion between peak value and dB value of raw data, different methods use different conversion formulas and units. The most commonly used units are dBmV, dBuV and dBm. In field operations, whether it is laboratory or front-line work, dBmV and dBuV are often abbreviated as dB together.

Ultrasonic signal conversion method: Compared with the transient ground voltage method, the amplitude change of the ultrasonic signal of the high-voltage switchgear has a larger change span, ranging from 0.5uV to 100mV. The dBmV of the ultrasonic signal is measured with 1uV as the benchmark, including:

$$\text{dBuV} = 20 \log \left(\frac{V_m}{1\mu\text{V}} \right) \quad (1)$$

3.2 Statistical distribution function

In 1927, Frechet gave the definition of this distribution; in 1933, Rammner and Rosin used this method to study the distribution of crumbs; in 1951, the Swedish engineer and mathematician Waloddi Weibull described this distribution very systematically, thus this probability distribution is named after him, Weibull Distribution. Weibull distribution is a multifunctional distribution, which is used for modeling in a wide range of applications in engineering manufacturing, quality control, etc. The two-parameter Weibull distribution applied in this paper is mainly described by shape β and scale parameter α . From a scientific point of view, this distribution is a continuous probability distribution, and its probability density $f(x)$ is as follows:

$$f(x) = \frac{\beta}{\alpha} \left(\frac{x}{\alpha}\right)^{\beta-1} \exp\left[-\left(\frac{x}{\alpha}\right)^\beta\right] \quad (2)$$

The cumulative distribution function of the Weibull distribution is an extended exponential distribution function, and the cumulative distribution function is the integral of the probability density function, which can describe the distribution of random variables. In the cumulative probability plot, the fit is best when the fit is a straight line. Based on the above, the cumulative probability distribution function $F(x)$ of the Weibull distribution is as follows:

$$F(x) = 1 - \exp\left[-\left(\frac{x}{\alpha}\right)^\beta\right] \quad (3)$$

3.3 Choice of test degree parameter

The goodness-of-fit statistics Table 1 for various probability distributions is shown in the following table. The table below shows 6 probability distributions such as normal, lognormal, Weibull.

Table 1: Statistics of probability distributions

Parameters/Distribution	Normal	Index	Weibull	Three-parameter Weibull	Minimum extreme value	Lognormal
AD value	1.003	24.037	0.374	0.405	0.374	1.060
P value	0.011	0.003	0.250	0.244	0.250	0.008

There are two test degree parameters, namely AD value and P value: AD value, the English name Anderson-Darling statistic, measures the degree to which the data obeys a specific distribution. The better the distribution and data fit, the smaller the statistic; the P value is the abbreviation of the English name Probability value, the assumed value, the assumed probability, and the P value indicates the degree of support of the sample evidence for rejecting the null hypothesis. The smaller the p-value, the stronger the evidence against the null hypothesis. The P value is usually compared with the significance level. If the P value is less than or equal to the significance level, it is concluded that the data does not obey the distribution; if the P value is greater than the significance level, it is concluded that the data obeys the distribution. It is assumed that the null hypothesis is true (that is, it obeys this distribution).

Since the P value has a value of 0.05 as a measurement standard, the P value is mainly used to judge the accuracy of the data, and the AD value is used as an auxiliary observation. Based on the above, only the Weibull distribution, the three-parameter Weibull distribution, and the minimum extreme value distribution meet the requirements. The AD value is used to assist judgment, and the AD value of the three-parameter Weibull distribution is too large and discarded.

The Weibull distribution and the minimum extreme value distribution AD value are similar in size. The minimum extreme value distribution type is widely used in the distribution of natural states, such as financial markets, rainfall research, meteorological research, etc. The research on precipitation, rainstorm, drought and flood in each region has It has a very broad meaning; and in terms of partial discharge of electrical equipment and the life of insulating materials, it is subject to Weibull distribution. At the same time, partial discharge is a physical process in which the insulation is lost and is affected by many different and accidental factors and is highly random. Therefore, this paper will systematically study and discuss the two distributions respectively.

4. Research and Analysis of Partial Discharge Signal Threshold of Switchgear

4.1 Weibull distribution threshold analysis

According to the Weibull probability map drawn at each voltage level from the original data, a scatter plot of shape parameters and voltage levels is obtained, and the scatter plot is made into a table form, as shown in Table 2. As the voltage level increases, the shape parameters show a decrease, and the discharges are more dispersed and not concentrated near the scale parameters. The value of the discharge signal is more dispersed, and in the probability graph, the curve gradually becomes wider, and the shape parameter gradually becomes smaller. Even if there is a set of special data of 10.9kV, it does not affect the analysis of the overall trend. The discharge is more severe above 13.3kV. Therefore, it is recommended to set the threshold value of the shape parameter of the discharge along the surface of the switch cabinet to 56. The Table 2 below shows the relationship between voltage level, shape parameter and scale parameter under Weibull distribution.

Table 2: Parameters of Weibull distribution

Voltage class (kV)	Shape parameter (β)	Scale parameter (α)
7	77.94	99.21
8.4	75.74	99.86
9.4	58.05	99.9
10.9	61.92	100.1
11.8	54.24	99.96
13.3	55.25	100.3
14.5	57.61	100.3
17.3	55.47	100.2
18.4	51.33	100.2

Although there is only a small range of 99-100, the performance under different voltage levels is still different, and the difference is on the order of 0.1. When the scale parameter is 99-99.8, the discharge is not severe. When it is above 100, the discharge phenomenon occurs at a very high voltage level. Although there is a sudden high data of 10.9kV in the above figure, considering that it may be caused by the experimental error. In general, the experiment still has a general rule. Similarly, the discharge above 13.3kV is considered to be more severe. Therefore, the recommended value for the threshold value of creeping discharge is 100.

4.2 Minimum extreme value distribution threshold analysis

The smallest extreme value distribution is defined by the location parameter and the scale parameter, modeling the smallest value in the distribution of random observations. According to the analysis of multiple groups of voltage levels according to the original data, it is found that the minimum extreme value distribution is roughly equivalent to the Weibull distribution, and according to relevant literature, this distribution is often used to describe extreme phenomena such as minimum temperature and rainfall during droughts.

4.2.1 Location parameter threshold analysis

Table 3: Parameters of Minimum extreme value distribution

Voltage class (kV)	Positional parameter (β)	Scale parameter (α)
7	99.22	1.269
8.4	99.87	1.313
9.4	99.91	1.708
10.9	100.1	1.606
11.8	99.98	1.828
13.3	100.3	1.804
14.5	100.3	1.731
17.3	100.2	1.795
18.4	100.2	1.929

The position parameter 100 can be set as the threshold parameter for partial discharge along the surface of the switch cabinet. When the position parameter is higher than 100, the discharge becomes very severe. At this time, the power equipment should be arranged for immediate power outage, operation and maintenance; when the position parameter is between 99 and 100, the discharge occurs but is not severe. Planned maintenance and regular operation and maintenance should be established, so the parameter values of this distribution type can be used as a backup plan for the Weibull distribution results.

4.2.2 Scale parameter threshold analysis

As the voltage level increases, the scale parameter becomes larger and larger, and the minimum extreme value is used to study the distribution, and the scale parameter can be set to 1.8. If the minimum extreme value distribution of the applied data is fitted at the switchgear work site, the discharge is severe when the scale parameter is higher than 1.8, and a power outage maintenance should be arranged immediately. The distribution law of the minimum extreme value is consistent with the Weibull distribution in the signal data reflected in this experiment. Similarly, in the detection of the operating state of the switchgear of the power grid, this distribution can be used as an auxiliary reference for the result of the Weibull distribution, and a means of verification for the analysis of discharge results.

5. Conclusion

(1) Partial discharge under different voltages has high randomness, so in the distribution network, firstly, the switch cabinet is detected by an appropriate method, and the obtained signal is calculated to obtain the result of the dB value. When the scale parameter of the dB value released by the authorities is 99-100 after the Weibull distribution, partial discharge occurs, but the discharge voltage is not high and the discharge situation is not severe. The switchgear should send an early warning signal and enter the continuous discharge monitoring stage. In terms of power regulation of the power grid, planned maintenance should be arranged; when the scale parameter of the dB value released by the authorities after the Weibull distribution is higher than 100, severe discharge occurs, and the switch cabinet should issue an alarm signal, which will occur in such a harsh environment for a long time. Insulation breakdown, at this time, the switchgear should be powered off and repaired immediately.

(2) The shape parameters of the partial discharge signal of the switch cabinet after Weibull distribution can also be used as a tool for analyzing the operation situation. When it is detected that the shape parameter of the partial discharge signal of the switch cabinet is greater than 56, the discharge voltage is low, the partial discharge signal distribution is relatively concentrated, and the partial discharge is not severe, the power grid should arrange for planned maintenance of the switch cabinet and continue to monitor the discharge; When the discharge is severe, the insulation may be affected, and the power grid should immediately conduct power outage maintenance on the switch cabinet.

References

- [1] Wang Jiangwei, *High-voltage switchgear operating environment and the development of a comprehensive online monitoring system for partial discharge [D]*. North China Electric Power University, 2019
- [2] Yang Tao. *Application Analysis of Partial Discharge Live Detection Technology in 10kV Switchgear [J]*. *Technical Analysis*, 2018, 10 (middle); 67-68
- [3] Zhou Ling. *Research on partial discharge fault identification algorithm based on ultrasonic signal [D]*. South China University of Technology, 2013.
- [4] K. Xu, B. Jia, T. Li, Z. Wang and X. Liu, "Ultrasonic Pattern Recognition and Classification of Partial Discharge of Switchgear Based on Short-time Fourier Transform and Sparse Representation," 2020 IEEE 4th Information Technology, Networking, Electronic and Automation Control Conference (ITNEC), Chongqing, China, 2020, pp. 2094-2097, doi: 10.1109/ITNEC48623.2020.9085201.
- [5] Tang Ju, Wang Jing, Li Jian, et al. *Application of Weibull distribution in identifying transformer partial discharge [J]*. *Journal of Chongqing University (Natural Science Edition)*, 2002, 25(4): 87-90. DOI: 10.3969/j.issn.1000-582X. 2002.04.023.
- [6] Bu Kewei, Tang Jinghong, Mi Chuming, et al. *Application of Weibull distribution in GIS partial discharge identification [J]*. *High Voltage Electrical Appliances*, 2009,45(3):81-84,88.

- [7] Li Yanran, Qian Yong, Chen Xiaoxin, et al. *Research on Weibull Distribution Characteristics of Cable Partial Discharge* [J]. *Electrical Automation*, 2015, (5): 111-114. DOI: 10.3969/j.issn.1000-3886.2015.05.036.
- [8] *Statistical Technical Committee, IEEE Guide for the Statistical Analysis of Electrical Insulation Breakdown Data[s]*, IEEE Std930TM-2004
- [9] Montanari GC, Contin A. *PD source recognition by Weibull processing of pulse height distributions* [J]. *IEEE transactions on dielectrics and electrical insulation: A publication of the IEEE Dielectrics and Electrical Insulation Society*, 2000, 7(1): 48-58.
- [10] Cacciari M., Contin A.. *Use of a mixed-Weibull distribution for the identification of PD phenomena [corrected version]* [J]. *IEEE transactions on dielectrics and electrical insulation: A publication of the IEEE Dielectrics and Electrical Insulation Society*, 1995, 2(6):1166-1179.
- [11] Jacquelin J..*Inference of sampling on Weibull parameter estimation*[J].*IEEE transactions on dielectrics and electrical insulation: A publication of the IEEE Dielectrics and Electrical Insulation Society*,1996,3(6):809-816.
- [12] Yan Qian. *Application and Research of Partial Discharge Online Monitoring System for High Voltage Switchgear* [D]. Beijing: North China Electric Power University, 2016. DOI: 10.7666/d.D01071335.
- [13] Yin Deqiang. *Analysis on the internal discharge of 35kV switchgear and research on its transformation* [D]. Beijing: North China Electric Power University, 2015. DOI: 10.7666/d.D760108.
- [14] Hu Changmeng, Cheng Lin, Wang Hui, et al. *Experimental study on partial discharge detection of transformer bushings with typical defects* [J]. *Electric Porcelain Arrester*, 2021(2): 107-115. DOI: 10.16188/j.isa.1003-8337.2021.02.017.