

# Design and Simulation of an Octopus-like AUV

Jiayi Li<sup>1,a,#</sup>, Meng Zhang<sup>2,b,#</sup>, Minang Ouyang<sup>3,c,#</sup>, Chongxiao Jiang<sup>4,d,#</sup>,  
Mincan Ma<sup>5,e,#</sup>, Junhao Deng<sup>6,f,#</sup>, Xiaoqing Zhu<sup>7,g,#,\*</sup>

<sup>1</sup>School of Mechanical and Aerospace Engineering, Jilin University, Changchun, Jilin, China

<sup>2</sup>School of International Education, Changchun University of Technology, Changchun, Jilin, China

<sup>3</sup>School of Electrical Information, Southwest Petroleum University, Chengdu, Sichuan, China

<sup>4</sup>School of Electrical Engineering, Northeast Electric Power University, Jilin, Jilin, China

<sup>5</sup>Modesto Christian School, Modesto, California, America

<sup>6</sup>Chongqing No. Eight Secondary School, Chongqing, China

<sup>7</sup>Faculty of Information Technology, Beijing University of Technology, Beijing, China

<sup>a</sup>470421759@qq.com, <sup>b</sup>953026349@qq.com, <sup>c</sup>3034333611@qq.com, <sup>d</sup>481706837@qq.com,

<sup>e</sup>1556848096@qq.com, <sup>f</sup>3356440954@qq.com, <sup>g</sup>alex.zhuxq@bjut.edu.cn

\*Corresponding author

(#Co-first author) These authors contributed equally to this work.

**Abstract:** With the continuous advancement of technology, human exploration and excavation of the ocean have deepened. The use of Autonomous Underwater Vehicles (AUVs) to assist and replace human operations in complex marine environments is becoming increasingly popular. This paper presents the design and modeling of an octopus-like Autonomous Underwater Vehicle with multiple functions. Kinematics simulation of the vehicle is also conducted. The study begins by investigating the current research status of Unmanned Underwater Vehicles in various countries, followed by proposing an improvement plan based on an analysis of the advantages and disadvantages of different types of Unmanned Underwater Vehicles. Subsequently, inspired by the body structure of an octopus, a three-dimensional model is created using SolidWorks. The model is then imported into Adams for dynamics simulation. Constraints, drives, and forces are applied to the vehicle to simulate the underwater environment. The Adams simulation results demonstrate that the designed octopus underwater robot can successfully perform various underwater tasks, including ascending, descending, harmonic motion, turning motion, and sample collection.

**Keywords:** Bionic function, Octopus, AUV, Pendulum, Spherical appearance

## 1. Introduction

As the world population continues to grow, land resources are being consumed. As another major strategic space in addition to land<sup>[1]</sup>, the ocean not only contains rich biological resources and mineral resources, but also contains many unknown things waiting for human exploration<sup>[2]</sup>. In recent years, many countries around the world have increased the exploration and development of the ocean. Because of its vast space and complex environment, the ocean is difficult for human beings to explore by their own strength, so the Unmanned Underwater Vehicle (UUV) came into being, and it has become more and more important in human's exploration of the ocean<sup>[3][4]</sup>.

UUV is a kind of equipment that can float or walk underwater, has exploration ability and can use structures such as mechanical arms to perform underwater tasks<sup>[5]</sup>. The advantage of UUV is that it can perform many different kinds of complex tasks, in recent years, due to the breakthrough of hydrogen fuel cells and the improvement of battery capacity, the endurance of UUV is also guaranteed<sup>[6]</sup>.

UUV can be divided into Remote Operated Vehicle and Autonomous Underwater Vehicle according to their different structures:

### 1.1. Remote Operated Vehicle (ROV)

The ROV relies on umbilical cables to obtain power from the mother ship, which has the advantages of long underwater operation time and fast real-time data transmission. However, ROV is not completely autonomous, and it needs to be operated by operators through cables in the mother ship or control station.

The umbilical cables are crucial to ROV, and the slender cables floating in the sea become the most vulnerable part of ROV, which is easy to wind when performing tasks, thus greatly limiting ROV's range of activity and efficiency of operations<sup>[7]</sup>.

The development of ROV can be traced back to the 1960s<sup>[8]</sup>, when it was used for civilian work such as deep water exploration, wreck salvage and underwater cable laying, and after years of development, the development of ROV has been relatively mature. Here are some typical ROVs. Japan's KAIKO was a ROV developed by JAMSTEC in 2003 specifically for underwater exploration and survey, with a maximum diving depth of 11,000m<sup>[9]</sup>, but the cable was cut during an underwater survey in 2003, and KAIKO was lost. The e-UROPe of the RITMARE Flagship project in Italy is a frame type ROV, which is a good civilian ROV with a maximum diving depth of 250m and a size of 1000mm\*700mm\*600mm. It is small in size but can perform different tasks in different environments according to different tools it is configured with. It is capable of completing tasks such as underwater sample collection and underwater exploration<sup>[10]</sup>.

In general, the ROV has strong performance, and the cable connection ensures the reliability of energy transmission and communication, enabling it to complete many different kinds of tasks. However, due to the constraints of the cable, it is easy to tangle with other objects in the environment when performing tasks, and the movement is relatively lack of flexibility.

### **1.2. Autonomous Underwater Vehicle (AUV)**

AUV is another category of UUV, which, as the name suggests, have a certain degree of autonomy and can make decisions autonomously to a certain extent<sup>[11]</sup>. The biggest difference between it and ROV in structure is that there is no cable to connect with the mother ship, which improves the flexibility of AUV movement and enables it to operate in complex and narrow areas. It is a device integrating artificial intelligence, information fusion, system integration and other technologies. Due to the lack of reliable energy sources in the early years, the development of AUV is restricted to a certain extent. Now, due to the enhancement of battery capacity, AUVs can be gradually applied to operations in a wide range of ocean areas. In addition, AUVs can realize cluster operations and save energy due to their relatively low cost compared to ROVs<sup>[12]</sup>.

AUVs began to rise in the 1990s and are now developing rapidly in the world. The following are several representative AUVs. The AUTOSUB AUV developed in the United Kingdom is 5.5 meters long, has a displacement of 2.8m<sup>3</sup>, can dive to a depth of 6,000 meters, and carries a variety of sensors for Marine scientific research<sup>[13]</sup>. The Bluefin AUV series of underwater robots is an AUV developed by Bluefin Robotics. The Bluefin-21 developed by Bluefin Robotics plays a significant role in the search and rescue operation of the Malaysia Airlines Flight 370. With a length of 4.93 meters, a diameter of 533mm, a weight of 750kg, and a submersible depth of 4,500 meters, it is well suited for Marine investigation, search and salvage missions.

Nowadays, with the outstanding performance of bionics in different fields, many AUVs also try to combine with bionics to pursue the laws of biological evolution over tens of millions of years in order to seek breakthroughs in structure and design. For example, Stefanini C et al. developed a multi-joint bionic fish driven by changing the polarity of magnets based on Lamprey<sup>[14]</sup>, and Mathieu et al. developed a multi-joint robotic fish driven by DC motor, Amphi Bot III<sup>[15]</sup>.

The purpose of this paper is to imitate octopus, and to design an octopus-like AUV which can carry out underwater exploration and sample collection by combining bionics knowledge with AUV. The AUV has the characteristics of strong power and simple operation.

In Section II, the design idea of the octopus-like AUV is explained, and the 3D model is created by SolidWorks. Adams is used to import 3D models and conduct motion simulation of the AUV, including ascent and descend, harmonic motion, turning and the task of sample collection by mechanical arms, which will be presented in Section III. Section IV will summarize the work done.

## **2. Design**

In order to complete the underwater hydrological monitoring missions, the octopus-like AUV adopts eight fin-like pendulums to generate power. The specific structure is shown in Figure 1. The reason why the fin-like pendulum drive is used is because the traditional propulsion system generally adopts propeller or water jet motor, which produces loud noise. Driven by a fin-like pendulum motion, the AUV will not

have a great impact on the hydrological environment of the water area when performing underwater operations. It is worth mentioning that the common fin structure is flexible. The advantage of this is that the flexible fins can bring better cruising and maneuvering performance, but the disadvantage is that the flexible fins are greatly affected by the resistance of the water flow, which makes the power provided by it is relatively small. In order to meet the dynamic requirements, the octopus-like AUV uses rigid fin-like pendulums to provide strong power, and the interaction of eight rigid pendulums set at equal angles enables the AUV to move and steer.

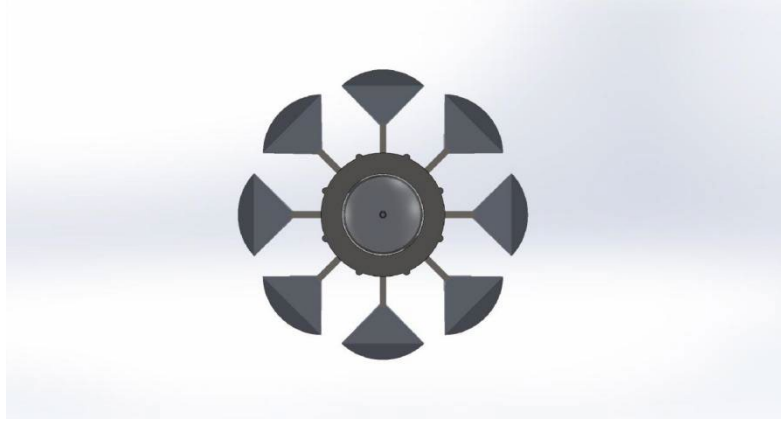

*Figure 1: Top view of the octopus-like AUV.*

In addition, in order to achieve the collection of marine biological samples, the octopus-like AUV has a container space driven by a hydraulic device at the bottom to store the samples. It also equipped with two mechanical arms to complete the collection operation. When performing the collection task, the container is opened, and the mechanical arm clamps the samples and places them in the container to complete the operation. The location of the container is shown in Figure 2.

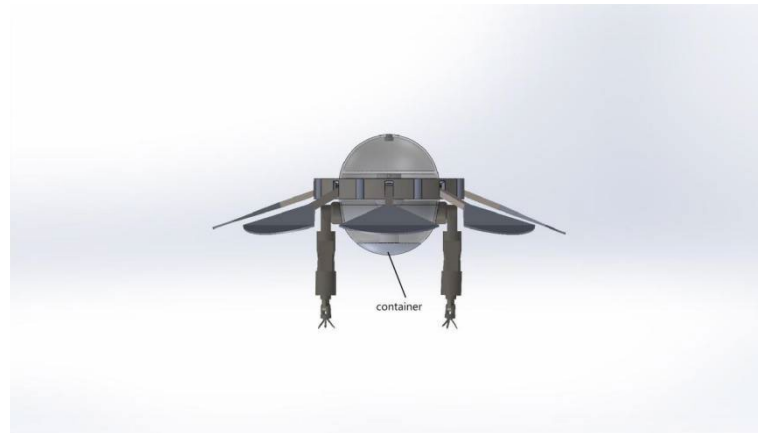

*Figure 2: Front view of the octopus-like AUV.*

The overall appearance design imitates the structure of octopus, with a circular outline as the main feature. The appearance is smooth, similar to marine organisms at the same time with a certain streamline, which can reduce resistance in the direction of movement, save energy, and have a certain degree of pressure resistance.

At the top and bottom of the main body, there are interlayers that can store water. The top layer achieves buoyancy change through water injection and drainage. The bottom layer not only has the same function as the top layer, but is also responsible for storing collected marine biological samples. Placing equipment such as laser radar, ultrasonic radar, control chips, and visual imaging system in the second cavity of the upper layer, using laser radar can depict the environmental image of the ocean area, making it convenient for AUV to plan their routes; Ultrasonic radar serves as a sonar for emergency obstacle avoidance functions; Visual imaging system can transmit real-time images from the ocean to the onshore control console, and the onshore personnel can control the movement in real time. Place the mechanical arms and lifting device in the second cavity of the lower layer. Maintain a strict sealing relationship between each cavity. The structure is shown in Figure 3.

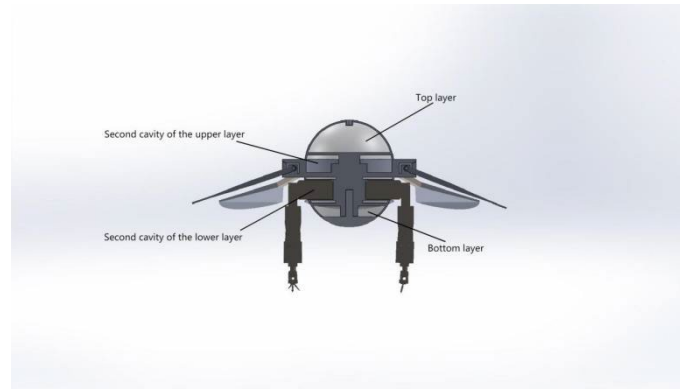

Figure 3: Section view of the octopus-like AUV.

The main part of the circular ring is used to place the steering gear, which drives the movement of the rigid fin-like pendulums. The movement angle of the steering gear is 50 °, and the reason for using the steering gear to drive is because of its high output accuracy, fast response speed, and large torque generated, which is suitable for frequently moving mechanisms.

The fin-like pendulums connected by the steering gear are installed at 45° to each other, allowing the device to move in multiple directions on its own horizontal plane and perform rolling movements in different directions in the vertical direction to complete turning. The eight pendulums can swing independently, simultaneously, or in a sinusoidal sequence.

The mechanical arms are composed of three joints that mimic a real arm and rotate around an axis, which provide it with a high degree of freedom. The clamping mechanism has three joints to increase the force when collecting samples, and different clamping forces can be used for clamping different marine biological samples.

The AUV is internally equipped with a gyroscope for positioning, and the control method adopts Fuzzy PID control. Term P reflects the deviation between the AUV's current pose and the target pose, while term I is equivalent to an amplifier. When term P is set too small, term I is used to compensate for the value of term P; Term D is equivalent to a suppressor, and term D can reduce the feedback value when the term P is too large or the joint action of term P and term I has a large overshoot. On this basis, fuzzy adaptive controller is added, and the error and error change rate of PID control are used as input, and fuzzy reasoning is performed to feedback and adjust the parameters of Term P, Term I and Term D. The specific manifestation of the comprehensive effect is to use Fuzzy PID control to overlap the body plane and the reference plane to adjust the posture when the body plane deviates from the predetermined reference plane.

The main structure used for visual imaging is made of organic glass, and the eight fin-like pendulums and two mechanical arms are made of aluminum alloy. They are lightweight and have good strength and corrosion resistance. Therefore, the size of the entire underwater robot includes fin-like pendulums diameter of 1.8m, height of 970mm, and a weight of approximately 115kg.

### 3. Simulation

#### 3.1. Ascent and Descent

The weight of octopus-like AUV is 115kg, and the volume of water when the top layer is filled can be expressed as equation (1):

$$V = \frac{\pi}{3} \times (3R - H) \times H^2 \quad (1)$$

where R is the radius of the top layer and H is the distance between the bottom surface of the top layer and the vertex of the top layer. Therefore, assuming that the average density of seawater is 1.05g/cm<sup>3</sup>, it can be calculated that the top layer can store 19 kg of water. The buoyancy of the entire AUV is calculated to be approximately 1300N by measuring the drainage volume of the AUV. Therefore when operating underwater, a balance between gravity and buoyancy can be achieved by controlling the amount of water injected.

The ascent can be accelerated by injecting a relatively small amount of water so that the gravity is

less than the buoyancy, or it can be achieved by flapping the eight fin-like pendulums of the AUV when the buoyancy and gravity are balanced. The concrete realization method is that the pendulums are initially at the bottom, and the ascent can be achieved by slowly lifting eight pendulums upward and quickly flapping them downward. The resistance of water can be express as equation (2):

$$F_r = 0.5\rho c s v^2 \quad (2)$$

where  $c$  is the fluid coefficient of the environmental medium,  $\rho$  is the density of the environmental medium,  $v$  is the flapping speed,  $s$  is the effective upstream area. To simulate the Marine environment  $c=1.18$ ,  $\rho=1.05\text{g/cm}^3$ . Because the speed of flapping downward is faster than lifting them upward, the resistance of the water is also greater. Therefore, the reaction force of the water on the pendulums' surface when flapping down will be greater than lifting them up, thus completing the upward floating. The specific values are the rising speed of the pendulum's center of mass at 1.45m/s, the falling speed of the pendulum's center of mass at 4.36m/s, and the period of flapping up for 0.8s and flapping down for 0.2s. The steering gear can meet this oscillation frequency. The data collected by the motion simulation are shown as Figure 4-Figure 6.

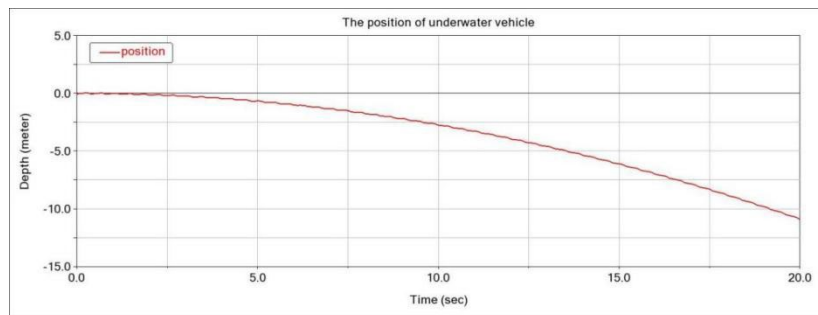

Figure 4: The relationship between the position of AUV's center of mass and time when AUV ascent.

Figure 4 shows that when the direction of depth increase is taken as the positive direction, it can be known that the AUV accelerates upward under the action of the set oscillating velocity of the steering gear.

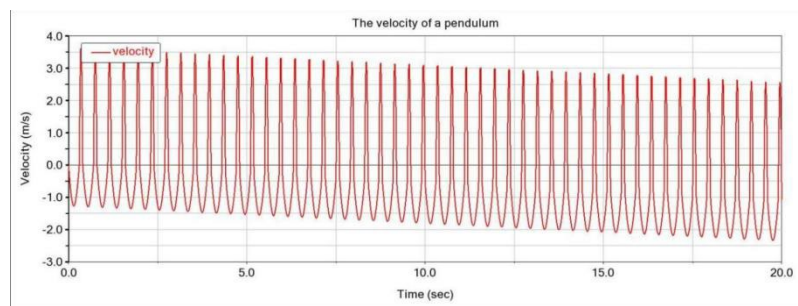

Figure 5: The relationship between pendulum's velocity and time when AUV ascent.

Figure 5 shows that the pendulum's velocity varies periodically, and the amplitude of each period changes because the speed of the AUV is superimposed.

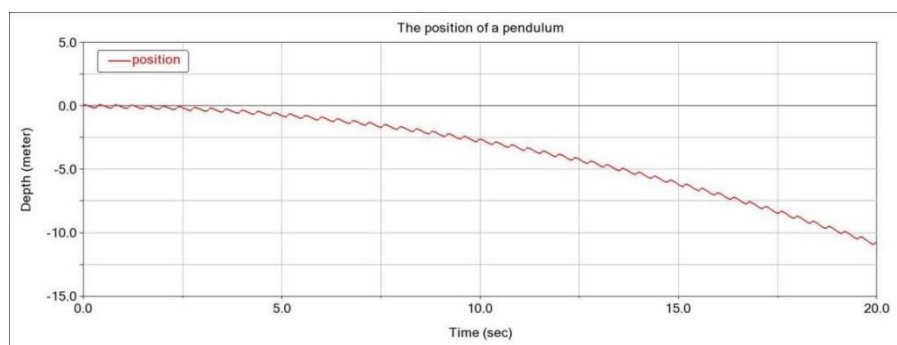

Figure 6: The relationship between pendulum's position and time when AUV ascent.

Figure 6 shows that the pendulum not only moves with the device but also oscillates periodically.

The descent can be accelerated by injecting more water so that the gravity is greater than the buoyancy. It can also balance gravity and buoyancy, using eight pendulums to achieve descent. The process is basically the same as ascent, only need to make the speed of flapping downward slower than lifting the pendulums upward. The period of flapping down for 0.8s and flapping up for 0.2s. The data collected by the motion simulation are shown as Figure 7-Figure 9.

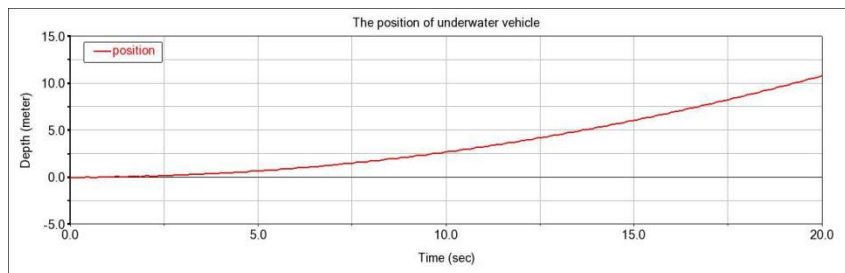

Figure 7: The relationship between the position of AUV's center of mass and time when AUV descent.

Figure 7 shows that when the direction of depth increase is taken as the positive direction, it can be known that the AUV accelerates downward.

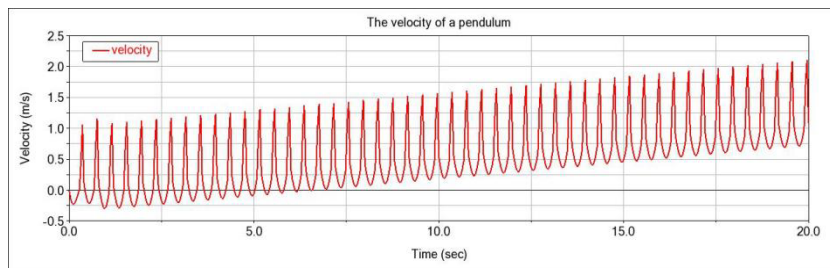

Figure 8: The relationship between pendulum's velocity and time when AUV descent.

Figure 8 shows that the pendulum's velocity varies periodically, and the amplitude of each period changes because the speed of the AUV is superimposed.

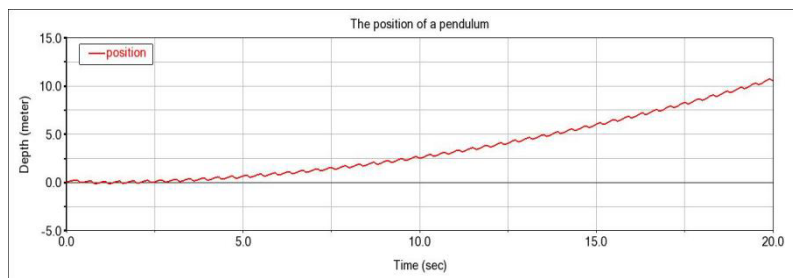

Figure 9: The relationship between pendulum's position and time when AUV descent.

Figure 9 shows that the pendulum not only moves with the device but also oscillates periodically.

### 3.2. Harmonic Motion

In order to realize the bionic function more vividly and get closer to the movement mode of octopus, the harmonic motion was chosen to simulate. Using ascent as an example to introduce harmonic motion. Dividing the eight pendulums into four groups, and two pendulums at  $180^\circ$  each other form a group as shown in Figure 10.

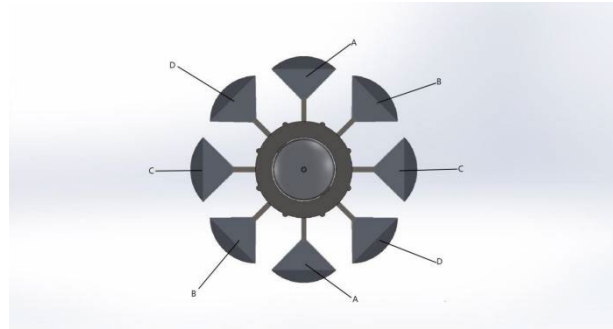

Figure 10: Grouping of the pendulums.

The phase difference between the two adjacent pendulums in the four groups is set to  $90^\circ$ , and the oscillations are performed in turn. Harmonic motion cannot be achieved by simply flapping up and down at different speeds, as in ascent and descent. It requires that all the pendulums exhibit stable harmonic motion. If the swing period is set to 0.4s, that is, the angular velocity is  $\omega \approx 15.7 \text{ rad/s}$ . The position equation of the pendulum can be expressed as  $\text{Cos}(15.7t + \phi)$ . The data collected by the motion simulation are shown as Figure 11-Figure 13.

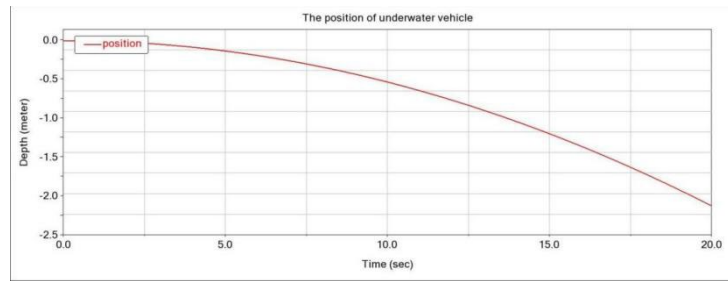

Figure 11: The relationship between the position of AUV's center of mass and time for harmonic motion.

Figure 11 shows that when the direction of depth increase is taken as the positive direction, it can be known that the AUV accelerates upward when it perform harmonic motion.

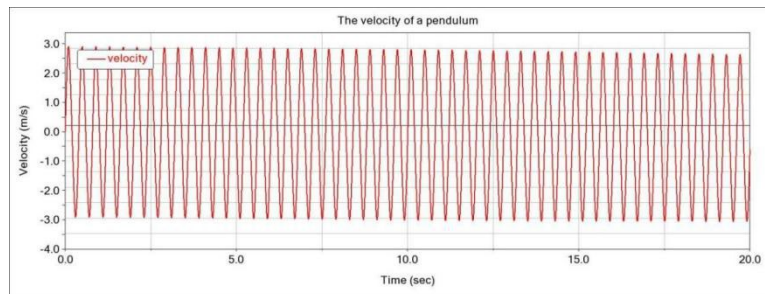

Figure 12: The relationship between the velocity of a pendulum and time for harmonic motion.

Figure 12 shows that the velocity of the pendulum varies periodically, but the power provided by harmonic motion is small, so even if the moving speed of the main body of the AUV is superimposed, the velocity of the pendulum still changes little.

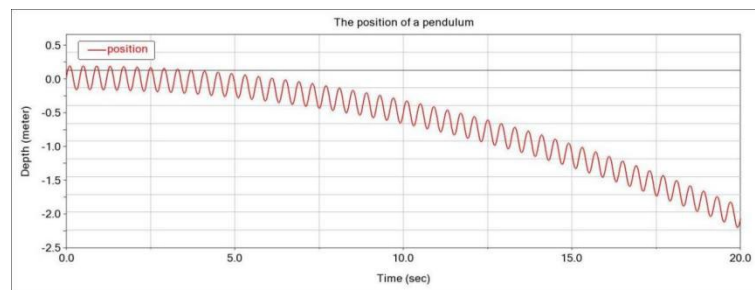

Figure 13: The relationship between pendulum's position and time for harmonic motion.

Figure 13 shows that due to the slow speed provided by the harmonic motion, the position fluctuation period of the pendulum is more obvious than that of eight oscillations at the same time.

In order to compare the simultaneous motion of eight pendulums and the harmonic motion of the octopus-like AUV, the first 10s of the position of the center of mass of the two motions are intercepted for comparison, as shown in Figure 14-Figure 15.

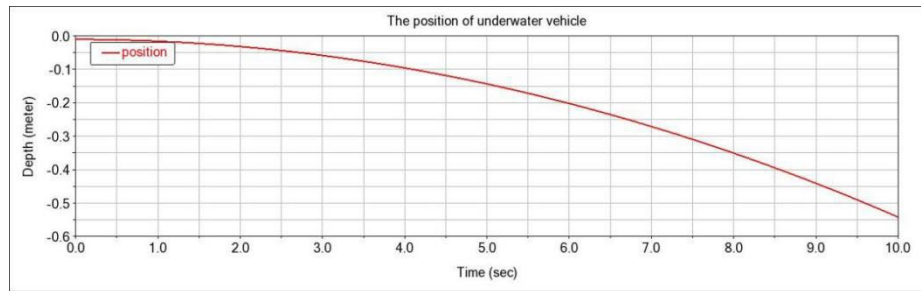

Figure 14: The change of the position of the center of mass in the first 10 seconds when eight pendulums flap simultaneously.



Figure 15: The change of the position of the center of mass in the first 10 seconds when harmonic motion.

Through comparison, it can be seen that the power provided by the simultaneous flapping of eight pendulums is greater than that provided by harmonic motion, but the stability of harmonic motion is much better than that of the simultaneous flapping of eight pendulums. The slow but steady harmonic motion and bionic shape make the AUV suitable for tasks such as observing the habits of marine organisms.

### 3.3. Turning

Based on the adjustment of the motion states of the eight pendulums, the turning of the AUV can be achieved by adjusting the flapping rate. After injecting water into the top layer to balance gravity and buoyancy. The resistance of water can also be calculated by the equation (2). Therefore, it is only necessary to control the four adjacent pendulums to flap in the same way and speed at the same time, while the remaining four are placed at the bottom of swing under the combined action of resistance and steering gear. The way of oscillation is similar to that of ascent. By slowly lifting the four pendulums on one side and quickly flapping them down, the differential velocity of water flow on both sides of the AUV is achieved to realize turning. Figure 16 shows the Angle between the plumb line of the AUV and the horizontal plane, and it can be seen that the rotating motion has been completed.



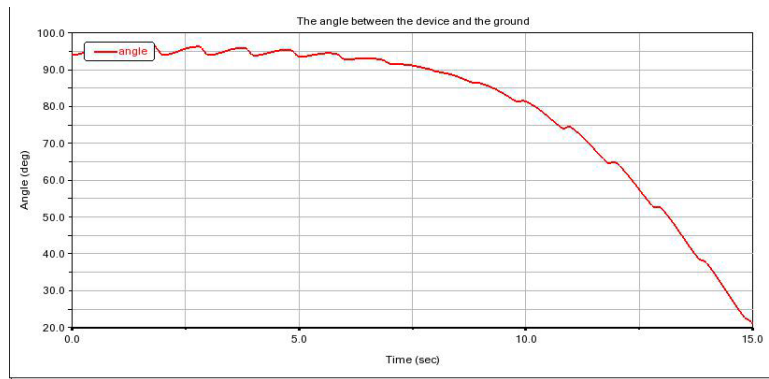

Figure 16: Angle between the plumb line of the AUV and the horizontal plane.

### 3.4. The Task of Sample collection

This section shows the AUV simulating sample collection work through process screenshots. A solid ball with a diameter of 10cm is established in Adams to simulate the required sample collection. Revolute pairs and drives are added to all joints of the mechanical arms to simulate the collection process. The clamping process is carried out through the collaboration of three joints as shown in Figure 17.

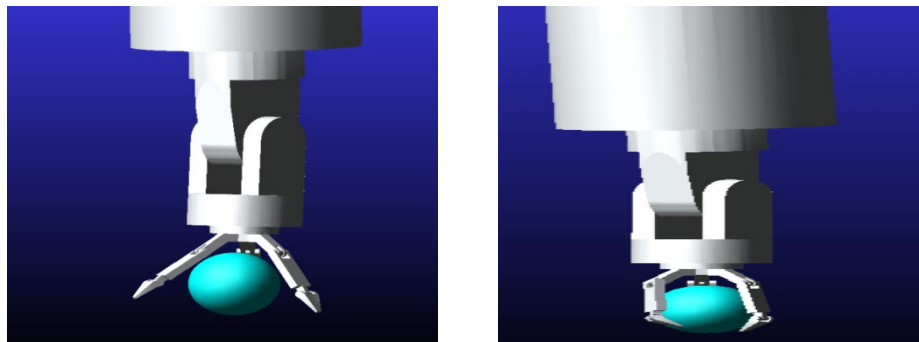

Figure 17: Grasping process.

The collection process is divided into seven steps. First, the big arm is lifted up to an appropriate angle. Second, opening the container downward. Third, when the forearm drives the mechanical arm up, the wrist of the mechanical arm rotates inward. Fourth, the mechanical arm releases the sample. Fifth, the mechanical arm rotates outward and moves out of the container. Sixth, closing the container upward. Seventh, the mechanical arm returns to its original position. The process is shown in Figure 18.

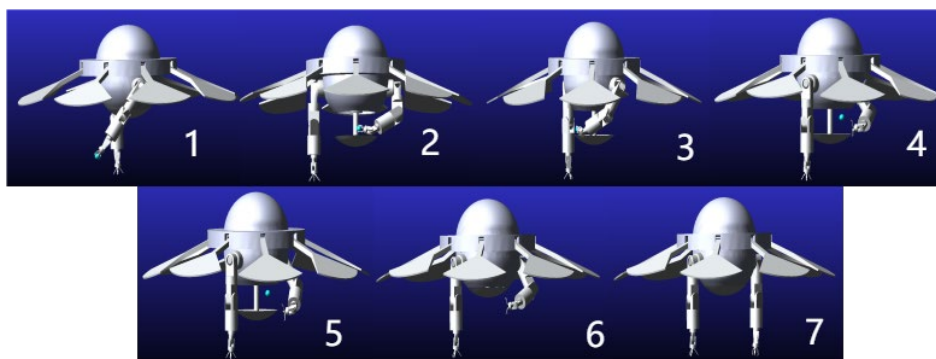

Figure 18: Sample collection process.

## 4. Conclusion

This paper introduced the design and simulation of an octopus-like Autonomous Underwater Vehicle (AUV) using SolidWorks and Adams. The AUV exhibits remarkable versatility and can effectively operate in various environments, including biologically rich lakes, shallow seas, and deep oceans,

carrying out tasks such as exploration, surveying, and sampling. Additionally, it has the capability for high-precision observations with observation devices and can participate in ecological research as part of biological clusters. The AUV serves as a multi-functional underwater platform with significant modification potential, allowing for adaptable configurations to suit different operational requirements and presenting promising avenues for research.

While the AUV design was inspired by the appearance of an octopus, it differentiates itself from typical octopus-like UAVs by innovatively utilizing rigid fin-like pendulums for propulsion. This design choice optimizes internal space, enabling the incorporation of additional functional equipment.

However, certain aspects of the proposed octopus-like UAV require further improvement. The usage of eight pendulums demands a substantial number of motors, leading to considerable energy consumption and challenging endurance. The device's overall size is relatively large, and its movement encounters more resistance compared to mainstream UAVs of similar size. Enhancing the fluid appearance design offers considerable potential for refinement. These areas will be the focus of future research efforts.

## References

- [1] Zhu Daqi & Hu Zhen. (2018). *Research status and prospect of deep-sea Submersible*. *Journal of Anhui Normal University (Natural Science Edition)* (03), 205-216. doi:10.14182/J.cnki.1001-2443.2018.03.001.
- [2] Wang Chaoqun, Mei Dan, Wang Yu, Yu Xiwen, Sun Wen, Wang Dong & Chen Junquan. (2022). *Task allocation for Multi-AUV system: A review*. *Ocean Engineering (P3)*. doi:10.1016/J.OCEANENG.2022.112911.
- [3] Cheng Chunxi, Sha Qixin, He Bo & Li Guangliang. (2021). *Path planning and obstacle avoidance for AUV: A review*. *Ocean Engineering*. doi:10.1016/J.Oceaneng.2021.109355.
- [4] Guo Yinjing, Liu Hui, Fan Xiaojing & Lyu Wenhong. (2021). *Research Progress of Path Planning Methods for Autonomous Underwater Vehicle*. *Mathematical Problems in Engineering*. doi:10.1155/2021/8847863.
- [5] Pere Ridao, Marc Carreras, David Ribas, Pedro J. Sanz & Gabriel Oliver. (2015). *Intervention AUVs: The next challenge*. *Annual Reviews in Control*. doi:10.1016/j.arcontrol.2015.09.015.
- [6] Zhang Bingbing, Ji Daxiong, Liu Shuo, Zhu Xinke & Xu Wen. (2023). *Autonomous Underwater Vehicle navigation: A review*. *Ocean Engineering*. doi:10.1016/J.Oceaneng.2023.113861.
- [7] Li Shuo, Wu Yuantao, Li Chen, Zhao Hongyu & Li Yiping (2022). *Application and Prospects of Underwater Robots* *Journal of the Chinese Academy of Sciences* (07), 910-920. doi:10.16418/j.issn.1000-3045.20220506001.
- [8] Wang Jianbin & Wang Zhimin (2007). *Development, Application, and Key Technologies of UUV* *Information and Electronic engineering* (06), 476-480.
- [9] Tetsuji Maki. (2006). *Development of Advanced Secondary Cables for the Kaiko*. *Sea Technology: Worldwide Information Leader for Marine Business, Science & Engineering*(7).
- [10] Angelo Odetti, Marco Bibuli, Giorgio Bruzzone. & Gabriele Bruzzone. (2017). *e-URoPe: a reconfigurable AUV/ROV for man-robot underwater cooperation*. *IFAC PapersOnLine*(1). doi:10.1016/j.ifacol.2017.08.2089.
- [11] Mae L. Seto (2012). *Marine Robot Autonomy*. Springer, New York, NY.
- [12] Zhao Qiaoqiao, Zhang Lichuan, Liu Lu & Pan Guang (2022). *Overview of key energy-saving technologies for underwater biomimetic robot clusters* *Journal of Northwestern Polytechnical University* (03), 576-583.
- [13] McPhail S, Furlong M, Huvenne V, Perrett J, Pebody M, Stevenson P. (2009). *Autosub6000: its first deepwater trials and science missions*. *Underwater Technology* (3). doi:10.3723/UT.28.091.
- [14] C Stefanini, S Orofino, L Manfredi, S Mintchev, S Marrazza, T Assaf. . . & P Dario. (2012). *A novel autonomous, bioinspired swimming robot developed by neuroscientists and bioengineers*. *Bioinspiration & Biomimetics* (2). doi:10.1088/1748-3182/7/2/025001.
- [15] Mathieu Porez, Frédéric Boyer & Auke Jan Ijspeert. (2014). *Improved Lighthill fish swimming model for bio-inspired robots: Modeling, computational aspects and experimental comparisons*. *The International Journal of Robotics Research* (10). doi:10.1177/0278364914525811.