

Appearance design of a table tennis cleaning and recovery machine

Zou Zhiheng¹, Li Weize¹, Shu Junhao¹, Liu Tongda¹, Louissi Delaunay Gloire Chancel¹, Xu Shuping^{1,*}

¹North China Electric Power University (Beijing), Beijing, China

*Corresponding author

Abstract: In the daily physical exercise of table tennis, the surface of the table tennis ball is often sunken or there are stains on the surface of the table tennis ball. The existing table tennis ball cleaning method is only manual cleaning. The staff takes a brush to rub the surface of the table tennis ball one by one. The cleaning efficiency is low, and the long-term work can not always ensure efficient cleaning. In addition, the table tennis ball with concave surface can only be restored by hot water flushing, which will cause waste of water resources and low efficiency. Therefore, a table tennis ball recovery and cleaning integrated machine device is proposed to solve the above problems. And because of the improvement of CAD/CAM, Computers can help designers take charge of calculations, information storage and drawing. So we decided to use Solidworks software to realize the appearance design of our all-in-one table tennis cleaning and recovery machine.

Keywords: Solidworks; CAD/CAD; Appearance design

1. Introduction

Table tennis plays a critical role in the game, but it is prone to damage and staining due to improper use and extended playing time. To address these issues and improve the durability of table tennis equipment, a new solution has emerged: the table tennis recovery cleaning all-in-one machine device, as shown in Figure 1 and Figure 2.

This innovative device is designed to restore and clean table tennis balls and surfaces, ensuring their longevity. It incorporates advanced technology to provide a cost-effective and efficient solution for table tennis enthusiasts.

The primary feature of the table tennis recovery cleaning^[1] all-in-one machine device is its ball recovery system. This system collects and restores stray balls, reducing the need for constant replacements and preserving the quality of the balls for longer periods of play.

In addition, the device includes a cleaning mechanism that effectively removes stains and dirt from the surface of table tennis balls. By using gentle but powerful cleaning agents, it not only improves the appearance of the balls but also enhances their performance.

The machine device is equipped with adjustable settings to cater to different cleaning requirements. Users can customize the intensity and duration of the cleaning process, ensuring that both lightly soiled and heavily stained table tennis balls receive the appropriate treatment. This versatility allows players to restore their equipment and optimize their playing experience.

Furthermore, the table tennis recovery cleaning all-in-one machine device is user-friendly and convenient. It has an intuitive control panel and a compact design, making it suitable for personal use at home or in training facilities. Safety features are also incorporated to prevent accidents and provide peace of mind to users.

In summary, the table tennis recovery cleaning all-in-one machine device is a significant advancement in maintaining table tennis equipment. By effectively restoring dented and stained balls, it enhances their durability and preserves their performance. This innovative solution offers convenience and cost-effectiveness, enabling players to consistently enjoy high-quality table tennis equipment.

2. Research objects and methods

2.1. Research objects

The research object is the table tennis used in the table tennis classroom of Chinese universities.

2.2. Research methods

In this paper, the appearance design of a ping-pong ball cleaning and recovery machine is completed by using the methods of literature review and modeling.

2.2.1. Literature method

This paper reviews and analyzes the domestic and foreign literature on solidworks and CAD/CAM technology, which provides references, academic background and scientific basis for this paper.

2.2.2. Modeling method

This paper uses solidworks software and CAD/CAM technology to complete the appearance design of a table tennis cleaning and recovery machine^[2].

3. Results and Analysis

3.1. Research results

3.1.1. Research background

3.1.1.1. Introduction to CAD/CAM technology

CAD/CAM technology is based on computer, peripheral equipment and system software. It includes 2D drawing design and 3D geometric modeling design^[3]. It is a method for designers to design with the help of computers. CAD/CAM technology is a result of the amalgamation of human creativity with high-speed computing, immense storage capacity and logical judgment abilities. It has fundamentally transformed modern manufacturing and engineering design, playing a pivotal role with broad applications and substantial significance. Its wide acceptance and continued development have sparked industrial revolutions, propelling technological innovation and advancements in various industries such as machinery manufacturing, aerospace, electronics, automotive, and medical equipment.

Solidworks software, a representative product of CAD/CAM technology, stands out as an exceptional solution renowned for its outstanding capabilities. It has earned a reputation as one of the finest CAD/CAM software packages, trusted by professionals worldwide for its extensive features and user-friendly interface.

The integration of CAD/CAM technology has revolutionized product design, engineering, and manufacturing. By facilitating precise modeling, simulation, and analysis, it empowers designers and engineers to develop intricate and innovative solutions with unparalleled accuracy and efficiency. As a result, product development cycles are accelerated, time-to-market is reduced, and overall product quality is enhanced.

Furthermore, CAD/CAM technology has revolutionized collaboration and interdisciplinary work, fostering seamless communication between diverse teams, including designers, engineers, and manufacturers. This ensures a streamlined workflow, minimizing errors and miscommunications. The software promotes higher efficiency, accuracy, and consistency throughout the entire product development process.

Solidworks, as a flagship CAD/CAM software, distinguishes itself through its extensive range of features, encompassing 3D modeling, simulation, documentation, and data management. Its intuitive interface and extensive libraries of pre-built components simplify the design process, enabling designers to bring their concepts to life swiftly and effectively. The software's robust simulation capabilities allow engineers to analyze the performance and behavior of their designs under various conditions, ensuring optimal functionality and reliability.

In conclusion, CAD/CAM technology has instigated remarkable transformations across industries, driving advancements and nurturing innovation. As an exemplary representative of this technology,

Solidworks software has played a crucial role in empowering designers and engineers with indispensable tools, facilitating the creation of groundbreaking products, streamlining workflows, and enabling unprecedented levels of creativity and efficiency.

3.1.1.2. Introduction to Solidworks

SolidWorks is a high-tech company specialized in developing 3D mechanical design software^[3]. The purpose of the company is to provide powerful CAD/CAE/CAM/PDM systems for design engineers. SolidWorks, the leading product of SolidWorks, is a world leader in 3D CAD software. In 1995, SolidWorks launched the first 3D CAD system developed based on Windows, and became the first computer platform CAD system in the world.

Promoted by SolidWorks, other relevant software has been successively launched at home and abroad. SolidWorks is also the first CAD company to develop automatic feature recognition FeatureWorks software and Internet based electronic drawing publishing tool (E-Drawing). In 1997, Dassault acquired SolidWorks with a wholly-owned capital of US \$310 million. After the merger, SolidWorks continued to operate independently, becoming a high-quality professional company.

SolidWorks Software has pioneered many innovative features, including top-down and bottom-up design. The ability to design relevant design sub components from top to bottom in the assembly environment, so that geometric shapes and components are fully automatic and relevant, and provide consistent interfaces and commands for designers in the fully automatic and relevant design environment. Bottom up design refers to the combination of all parts of a product into a designed product, which can also realize the full automation between geometric shapes and parts. The fully automated design environment provides consistent interfaces and commands.

In SolidWorks, users can use various modules and plug-ins, such as part library, feature tools, measurement tools, assembly tools and simulation tools, to design and build various types of 3D models. These tools can help users complete model design efficiently and carry out rapid simulation and analysis.

SolidWorks also provides a wealth of community support and training resources, including online tutorials, video training, community forums and professional training courses. These resources can help users better learn and master the use of SolidWorks, so as to improve their work efficiency and design quality.

In SolidWorks, configuration is a very convenient function. Users can create variations of multiple parts in a single part and assembly documents, and these parts can be displayed in the same assembly part at the same time. This function is very useful in the specific design process, such as whether the casting blank or the processed state of the part that realizes the sheet metal bending. In addition, SolidWorks uses configuration to capture changes and modifications in the actual design process, thus meeting a variety of design requirements. SolidWorks also created a real-time online 3D website (Partstream. Net) for Internet based 3D product catalog management and delivery services, as well as advanced functions such as SmartParts, flexible subassemblies, and alternate position views. This is because SolidWorks has powerful configuration management technology, and other similar software cannot support such advanced features.

In short, SolidWorks is a powerful three-dimensional CAD software, which has led the development of many innovative functions in the CAD industry. Driven by SolidWorks, the application of 3D CAD software has been widely popularized.

3.2. Appearance design

3.2.1. Cylinder modeling

- (1) Create on the xy plane $\phi 500$. Then stretch it into a cylindrical shape with a stretching ring.
- (2) Create with pipe command $\phi 50$, and then use the array command to array the tubes.
- (3) Combine the tube with the extruded cylinder, fillet, and then use the shell command to get the cylinder surface of the cylinder.
- (4) Create on the cylindrical face end face of the cylinder $\phi 50$, use the stretching command to get the end cover of the cylinder, and repeat the same command on the other side.
- (5) The above cylinder modeling is completed.

3.2.2. Modeling of bearing

- (1) Create a plane offset 30mm from the cylinder end cap surface.
- (2) Create a box on a plane, and then use the extrude command to create the box.
- (3) Extract the outer contour surface of the cylinder, and then use the trim command to cut the box to get the support.
- (4) Then use the mirror command to get two symmetrical supports.
- (5) The support modeling is completed.

3.2.3. Funnel modeling

- (1) Create a plane 30mm directly above the cylinder.
- (2) Create on a plane $\phi 50$, and then use the extrusion command to create a cylinder.
- (3) At distance ϕA 50 mm cylinder creates a plane.
- (4) Create on a plane $\phi 100$, use the extrusion command to create a cylinder.
- (5) Use the ruled command to $\phi 50$ cylinder and $\phi 100$ columns.
- (6) Use the merge command to merge the three parts.
- (7) Use the shell pulling command to obtain the funnel with a thickness of 5mm.
- (8) Funnel^[4] modeling is completed.

3.2.4. Modeling of motor support plate

- (1) Create a plane 200 mm from the xy plane.
- (2) Create a rectangle on a plane and extrude the support plate with the extrusion command.
- (3) Chamfer the support plate.
- (4) The modeling of support plate^[5] is completed.

3.2.5. Universal wheel and motor modeling

- (1) Universal wheel^[6] and motor^[7] are downloaded standard parts, which are assembled with import and assembly commands.

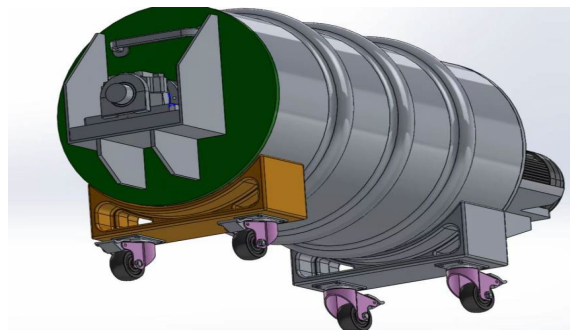

Figure 1: Finished product of appearance design (self-made)

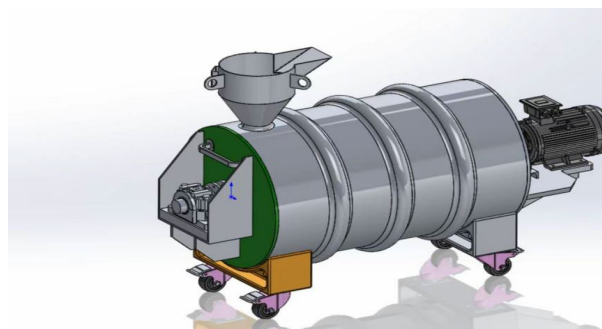

Figure 2: Finished product of appearance design (self-made)

4. Conclusions and suggestions

The development of an all-in-one machine for table tennis recovery and cleaning has solved the issue of concave surfaces and stains on table tennis balls during training. This groundbreaking device restores the ball's smooth surface, eliminating deformities caused by wear and tear. It also efficiently cleans any stains, improving the ball's appearance and performance. By automating the recovery and cleaning processes, the machine saves time and effort, allowing players to focus on their game. This technological breakthrough sets a new standard in table tennis training equipment, ensuring a consistent and optimal playing experience.

It fills the shortcomings of low mechanization and low practicability of innovative products in the existing market products. If the table tennis recovery and cleaning machine is equipped during daily training, the efficiency and scientificity of training will be greatly improved, which will be more conducive to the good development of table tennis in China.

The integration of an all-in-one table tennis recovery and cleaning machine effectively improves the reuse rate and durability of table tennis balls, while also reducing extra expenses in the process of physical exercise. By restoring the smooth surface of worn-out table tennis balls, the machine eliminates deformities and allows for extended usage, reducing the need for frequent ball replacements. Additionally, its efficient cleaning capabilities ensure that the balls remain free from stains and dirt, further enhancing their lifespan. These benefits result in significant cost savings for both professional players and recreational enthusiasts, as they can prolong the lifespan of their table tennis balls, avoiding the constant purchase of new ones. Moreover, the machine streamlines the ball recovery and cleaning process, saving time and effort for players, coaches, and training facilities. This enables them to focus more on practicing and improving their skills, optimizing their training sessions. Overall, this all-in-one machine promotes sustainability, reduces expenses, and enhances the efficiency and longevity of table tennis equipment.

References

- [1] Yang Zhichun, Liu Bao, Lu Zhimin et al. *A kind of recycled aluminum substrate cleaning agent research [J]. China cleaning products industry, 2023 (05): 33-37. DOI: 10.16054 / j.carol carroll nki. Cci. 2023.05.009.*
- [2] Li Hailin, Bai Shanshan, Chen Shiwen, Fang Liujun, Lu Junhao. *Analysis on the appearance design of computer mouse [J]. Journal of Jiamusi Vocational College, 2019 (12): 210-211*
- [3] Wang Shaohua. *On the Application of 3D Design Software in Mechanical Teaching [J]. China New Communication, 2020,22 (05): 202*
- [4] Zuo Hongchuan, Wu Yuhui. *Structural design and optimization of torque support plate of roller press [J]. Cement Engineering, 2022 (06): 10-12+28. DOI: 10.13697/j.cnki.32-1449/tu. 2022.06.003*
- [5] Ma Chao, Gai Yongling, Zhang Lifeng, Liang Qian. *Design and development of portable car moving device [J]. China Equipment Engineering, 2022 (10): 112-114*
- [6] Zhu Tinglou, Sun Hongqing. *Application and Practice of Intelligent High efficiency Energy saving Motor System [J]. Energy Research and Utilization, 2022 (04): 52-55. DOI: 10.16404/j. cnki. issn1001-5523.2022.04.002*
- [7] Wang Xiaoyan. *Table Tennis Characteristics of Nano modified Plastic Materials [J]. Plastic Additives, 2022 (05): 32-35*