

Research on Electromagnetic Compatibility Testing Technology of Electronic Products

Zhongxi Ding¹, Hao Zhong¹, Jiani Mo²

¹Changsha Customs Technology Center, Changsha 410004, Hunan, China

²Shenzhen Learning Without Borders Education Technology Co., Ltd. (Changsha), Changsha 410005, Hunan, China

Abstract: *In recent years, the electronics industry is developing rapidly, and many electronic products have emerged. Electromagnetic compatibility is the basis for ensuring product suitability. In order to ensure the electromagnetic compatibility of electronic products, it is necessary to play the role of testing technology to clarify the electromagnetic compatibility effect. This paper combines the concept of electromagnetic compatibility, analyzes the method of electromagnetic compatibility detection from the technical level, and combines the application of technology to improve the reliability and safety of electronic products.*

Keywords: *Electronic Products, Testing Technology, Electromagnetic Compatibility, Technical Application*

1. Introduction

The compatibility of electronic products means that the products can still operate normally and stably under the influence of specific factors, and will not be affected by other types of electronic products in the area. They have anti-interference effects and will not affect the stable operation of other products. In order to determine whether an electronic product has electromagnetic compatibility, it is necessary to evaluate it with the help of testing technology to determine the reliability and safety of the electronic product in terms of electromagnetic compatibility.

2. Evaluate the importance of electromagnetic compatibility

2.1 To guarantee the working state of electronic products

Electromagnetic compatibility means that electronic equipment and systems can still operate normally according to the design requirements under electromagnetic influence, and will not cause damage to other equipment in the surrounding environment, or can withstand electromagnetic interference [1]. The technical requirements of electromagnetic compatibility are reflected in two points. First, the equipment needs to ensure that the intensity of electromagnetic waves generated in the surrounding area is below the safe value under working conditions, and the electronic product itself can resist the interference signals generated by other electronic equipment in the area. The interference effect caused by electromagnetic signals is that the protection level of the equipment is reduced, the sensitivity is higher, the effect of resisting interference signals will be reduced, and electronic products cannot work normally after being interfered with. Therefore, the production of electronic products must ensure the level of electromagnetic compatibility. Electronic products can maintain a stable state after being subjected to electromagnetic interference, and can also eliminate adverse effects on other electronic devices.

2.2 To be conducive to the protection of personal safety

Electromagnetic waves are everywhere in the living environment of human beings. Electromagnetic waves have played an important role in promoting the development and progress of society. The development of electromagnetic wave resources has realized its application value, but it has also caused a negative impact on human life. If electronic products in a local area are unreasonably designed, they will emit electromagnetic waves that do not meet safety standards during operation,

which will have a serious impact on human health. With the advancement of technology, a variety of electronic products, such as mobile phones, computers, televisions, washing machines, refrigerators, etc., have appeared at present. These different kinds of home appliances have played an important role in daily life, and have various roles in promoting social progress. When electronic products are in working state, they will emit electromagnetic waves of a certain intensity, which will cause interference. If these interference waves are too high and exceed the safe value, combustion may occur, and if they are too high, explosions may occur, posing a personal safety hazard [2]. The physical and chemical effects of electromagnetic energy also affect the normal physiological metabolism of the body. Therefore, detecting the electromagnetic compatibility effect of electronic products plays an important role.

3. Contents of electromagnetic compatibility testing

3.1 Testing of the electromagnetic compatibility of the power supply

Detecting the electromagnetic compatibility effect of the power supply can ensure that the design of the product achieves better results. If the power supply is interfered by other electronic devices in the area during operation, it can be determined whether it is affected and whether its performance is weakened by means of detection. Testing can determine its immunity to surge voltages. The detection method is to artificially apply different levels of surge voltage to the power supply under experimental conditions, and apply the same waveform voltage to the power cord and the casing at the same time, to detect whether the power supply can be guaranteed reliable when it is subjected to external interference [3]. Under normal conditions, the power supply enclosure will be in poor condition or destroyed after being disturbed. For example, the instantaneous breakdown of the power line indicates that the filter selection in the power supply is not good, the tolerance of the input terminal is insufficient, or the electronic product may lack a filter.

3.2 Testing of radiation

Detecting radiation can determine whether excessive electromagnetic radiation is emitted when an electronic product is in a working state, and detect whether the electromagnetic radiation generated by the product is harmful to surrounding people or electronic products. The detection of radiation can be carried out in a relatively simple way, which is also the easiest way. For example, if the channel of an ordinary radio is adjusted to AM mode, if there is electromagnetic interference, the noise in the radio can be identified. This method can be used for the detection of mobile phones or computers. For computer detection, the state stipulates that the radiation dose cannot be higher than 12V/m.

3.3 Testing of external magnetic interference

Detecting external magnetic interference can know whether electronic products have the ability to resist electromagnetic interference, and whether it will be affected or even damaged after being subjected to electromagnetic interference. They can be detected and analyzed by means of the radiation generated by the interference of radio frequency electromagnetic fields. The common method of testing is to place electronic products in a dark environment to maintain a stable state, and then apply interference signals to them, but the interference intensity should not be too large, electronic products must be safe, and the interference must be able to act continuously. Observe the influence of electromagnetic waves. Whether the performance of the electronic product has been affected and whether it is in a normal state. If there is a problem, it is necessary to analyze the defects of the product and improve it. For example, isolation measures should be taken for particularly sensitive electrical components in the product, which has anti-interference ability [4].

4. Application of Electromagnetic Compatibility Testing Technology

4.1 Electrostatic discharge immunity

Electrostatic discharge often adopts two methods, one is to realize DC contact discharge by direct contact, and one can also use air discharge. In the laboratory, it is necessary to ensure that the voltage can be effectively controlled, and the critical value can be determined in the event of electrostatic discharge failure. Electrostatic discharge testing requires the equipment to be placed in the detection

circuit (Figure 1). Detection can be performed with a single discharge. In the preset mode, it is necessary to ensure that the number of single discharges is not less than 10 times. In this experiment, it is necessary to ensure that there is a certain interval time for a single discharge. The most understandable condition is to ensure that the interval time is greater than 1 S. When testing, ensure that the system itself is in a good state and will not be affected by electromagnetic interference. After the electrostatic discharge immunity test is implemented, the analysis results should be combined with the characteristics of the electronic product to determine the conditions of performance degradation or functional failure under the test conditions. Specifically, it can be divided into various types: the performance of the product is degraded or the additional functions are limited under the action of the interference signal, and it can return to the normal state by itself after the interference signal is eliminated, which can be realized without human factors; the performance of the product after being subjected to electromagnetic interference It has been reduced to a certain extent, and the function has been limited to a certain extent. After the interference signal is removed, manual intervention is required to restore to the original state; under the action of the interference signal, the product is damaged or the function is lost, and there is an irreparable fault. In view of the damage caused by electrostatic discharge, electrostatic discharge can be solved in a variety of ways. If the cable used in the product must have a shielding function, try to use a cable with anti-electromagnetic signal or good shielding effect, and take protective measures for sensitive components. A protection circuit can be designed in the circuit to effectively suppress the interference caused by electrostatic discharge.

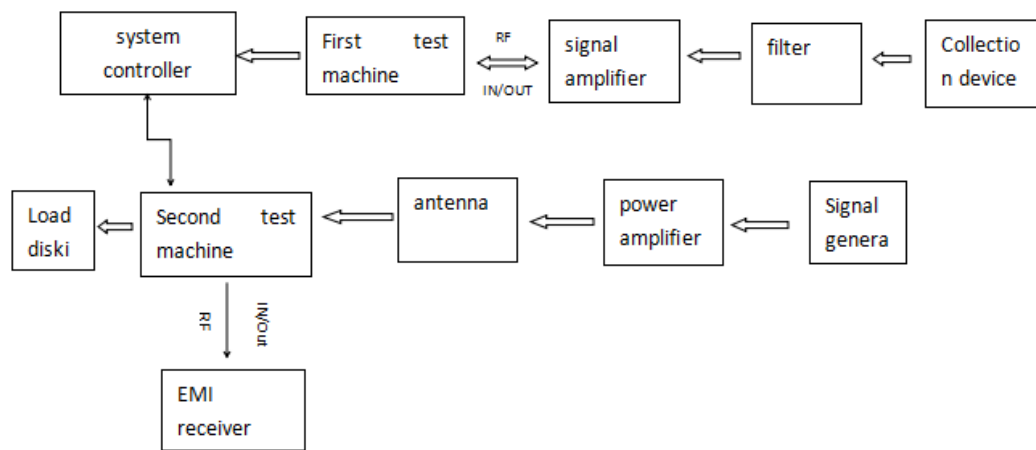

Figure 1: Detection flow chart

4.2 Transient impulse immunity

For the implementation effect of transient impulse immunity, the detection is implemented during the disconnection of the inductive load. The breakdown of the switch contacts and the bounce after an electric shock will have a great impact, so there will be an electrical pulse group at the moment of disconnection. Under the condition of electromagnetic induction, when the load is repeatedly opened and closed, the electrical pulse group will be repeated. Detection can determine whether electronic products are affected by transient electrical pulses, whether their performance has changed under the action of a magnetic field, and whether components have been "damaged". Under the condition of transient electrical pulse, the signal energy is low, and the electronic product is less likely to be damaged. However, if the frequency range of the electric pulse itself is wide, the stable state of the electronic product will be affected, and its stability and reliability cannot be guaranteed. The criterion for transient burst detection immunity is the severity of the damage, which is evaluated on the basis of whether it can be artificially recovered or the severity of the damage. For the solution of the transient pulse group, it can be realized by optimizing the circuit. When designing electronic product circuits, there should be a safe interval between strong and weak currents, and cables should not cross or overlap. Interfering circuits and sensitive circuits should be kept at a safe distance. In circuit design, additional filtering equipment can be used, and additional electromagnetic wave absorbing devices can be used to reduce the impedance value of the ground wire.

4.3 Surge immunity

Before the surge immunity test, the state of the surge generating device and the effectiveness of the coupling network should be determined first. After there is no abnormality, the number of surges and the intensity level of the interference test should be determined. The test method is to manually input the waveform voltage at the power port. The voltage amplitude is 1 kV, the pulse width is set to 50s, and the waveform voltage is input five times. The detection of the power supply shell and power line can be done by inputting the waveform voltage. If there are no special requirements for electronic products, the surge immunity test should ensure that the positive and negative electrodes must be connected for 5 times. The surge test acts on the power port, and the electromagnetic pulse signal is input under different phase conditions. During the surge test, the pulse Signals should occur at intervals of less than 1 minute or less. To implement the surge interference test, you can choose to connect the absorption equipment in parallel with the equipment to be protected, and the voltage can be automatically disconnected when the voltage exceeds the set threshold, and will not be damaged by overvoltage.

5. Conclusion

The electromagnetic compatibility of electronic products plays an important role, which is directly reflected in the reliability and stability of the equipment, and also affects its safety, market recognition and promotion effect. For this reason, electronic products should pay attention to the detection of electromagnetic compatibility in the manufacturing process, and combine the detection results to provide a reliable basis for design optimization. For the improvement of electromagnetic compatibility, enterprises should play a role in promoting technological progress and continuously improve the electromagnetic compatibility effect of electronic equipment.

References

- [1] Wang Hui, Qin Qingsong, Chen Naikuo, Geng Shihua. *Application of Electromagnetic Compatibility and Protection Technology of Electronic Products [J]. Science and Technology and Enterprise. 2015, (24): 191.*
- [2] Wang Fei. *Electromagnetic Compatibility Countermeasures for Electronic Products [J]. CHINA METROLOGY. 2005, (06): 53+56.*
- [3] Zhao Lei. *Electromagnetic compatibility (EMC) design of electronic products [J]. SCIENCE AND TECHNOLOGY OF HOUSEHOLD ELECTRIC APPLIANCE. 2000, (04): 41-43.*
- [4] Xing Kui, Xue Menglin, Wang Yawei. *Application of Wireless Receiver's EMC Fast Testing Technique in Complicated Electromagnetic Environment. [J]. Journal of Astronautic Metrology and Measurement, 2015, (5): 21-26.*