

# Optimization of Hybrid Energy Storage Capacity for Electric Vehicle Photovoltaic Charging Stations based on Multi-Objective Quantum Particle Swarm Optimization

Jicheng Liu<sup>1,3</sup>, Qiongjie Dai<sup>1,2,3,\*</sup>

<sup>1</sup>School of Economics and Management, North China Electric Power University, Changping, Beijing, China, 102206; ljch@ncepu.edu.cn

<sup>2</sup>School of Mathematics and Computer Engineering, Ordos Institute of Technology, Ordos, Inner Mongolia, China, 017000;

<sup>3</sup>Beijing Key Laboratory of New Energy and Low-Carbon Development (North China Electric Power University), Changping, Beijing, China, 102206

\*Correspondence: daiqiongjie@yeah.net

**ABSTRACT.** An optimized allocation method of hybrid energy storage capacity has been proposed aimed at the random and intermittent characteristics of photovoltaic power generation in photovoltaic charging stations of electric vehicle. The method aims at maximizing the annual net profit of photovoltaic charging stations of electric vehicles and the photovoltaic consumption rate, and then establishes an optimization allocation model of multi-objective hybrid energy storage capacity. In this paper, an improved MOPSO is used to solve the Pareto solution for optimal allocation of the capacity of a hybrid energy storage system, and an improved TOPSIS algorithm is used to select the optimal solution in the Pareto optimal solution set as well. Through examples, the simulation is performed in two scenarios of single energy storage and hybrid energy storage. The simulation result shows that hybrid energy storage can reduce costs and promote photovoltaic energy consumption. Finally, the results of the improved algorithm are compared with the basic MOPSO, which verifies that the proposed algorithm is more effective and reasonable.

**KEYWORDS:** Multi-Objective Quantum Particle Swarm, Hybrid Energy Storage Capacity, Electric Vehicle Photovoltaic Charging Stations

## 1. Introduction

The use of renewable energy and electric vehicles has great potential for energy saving and emission reduction. The fluctuating and intermittent characteristics of

photovoltaic generation make it difficult for large-scale grid connection. At present, China's primary energy is still dominated by coal. When a great number of electric vehicles are connected to the power grid to charge and increase the burden on the power grid, carbon emissions cannot be effectively reduced, and the improvement of energy and environmental issues are not so obvious. PV based charge station(PBCS)is an important way to enhance the value of photovoltaic power generation and achieve the goal of energy saving and emission reduction. [1,2 ]. However, as the instability of photovoltaic power generation, it is necessary to integrate energy storage systems in PBCS to improve the utilization rate of photovoltaic power generation systems. Certain studies developed optimization techniques for integration of PV, energy storage and EV charge station. Chen et al. [3] proposed a multi-objective optimization model for capacity configuration considering PV utilization ratio and the cost of the systems. The frontier of non-dominant solutions and multiple Pareto optimal solutions are obtained through NSGA-II algorithm. Lu et al. [4] proposed a model for determining the energy storage capacity of PBCS with objective of minimum annual cost. The correlation of PV power and EVs charging load was consider. Vinit Kumar et al. [5] presented off-grid PBCS and simulated on MATLAB/Simulink environment to verify the system performance. Luo et al. [6] formulated a model to simultaneously design charging stations, PV plants, and time-dependent charging fee. A surrogate-based optimization algorithm is adopted to solve the model.

However, most of the above literatures consider the operation mode, economic benefits, and capacity allocation of photovoltaic charging stations from the perspective of grid connection, how to solve the energy storage type and capacity allocation of photovoltaic charging stations in non-grid connection mode is still failure. To overcome these challenges, the contribution of this article:

- 1) Detailed modelling of the off-grid PBCS. Formulation of a multi-objective optimization (MOO) problem to maximize the Annual profit of the station and the consumption of PV.
- 2) A Hybrid energy storage system (HESS) including batteries and super capacitors is applied to smooth the PV power fluctuations.
- 3) An optimization algorithm which combines Multi-Objective Quantum Particle Swarm Optimization (QMOPSO) and TOPSIS method is proposed to solve the above model and select an optimal solution from Pareto solutions.

Further,the paper is structured as follows. Section 2 describes the structure of off-grid PBCS. Section 3 HESS models is presented consider the annual profit and utilization rate of PV. Section 4 describes the optimization methodology and how it solves the problem. A case is studied and discussed in Section 5. Finally, Section V comes with the conclusion and the possible future work.

## **2. System Structure and Operation Strategy**

Photovoltaic charging station system of electric vehicles includes photovoltaic

power generation unit, vehicle charging unit and hybrid energy storage unit containing battery and super capacitor, the system structure is shown as in Figure 1.

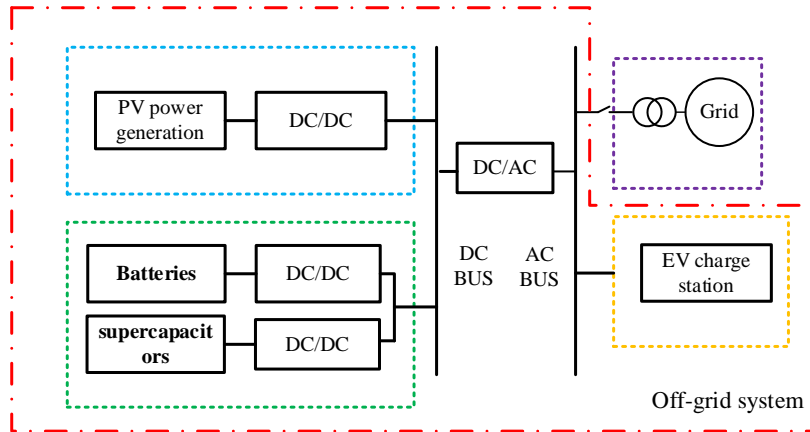

*Fig.1 PV-Based charging station structure*

Combine photovoltaic power generation and electric vehicle charging power as equivalent load power. When the equivalent load power is more than 0, hybrid energy storage system starts charging, or discharges on the contrary. Since the different characteristics of battery and super capacitor, the response power range to the equivalent load is different. The battery is charged and discharged at the rated power, while the super capacitor handles the remaining power fluctuations.

### 3. Capacity Optimization Model of Hybrid Energy Storage System

#### 3.1 Economic Analysis of Energy Storage System

The costs of energy storage system  $C_{HESS}$  mainly include construction cost  $C_i$ , operating costs  $C_o$ , maintenance cost  $C_m$  and processing cost  $C_d$ , the calculation of each cost is as shown in formula (1).

$$C_{HESS} = C_i + C_o + C_m + C_d = E_{ba}C_{ba}CRF_{ba} \times m \times (1 + k_{oba} + k_{mba} + k_{dba}) + E_{uc}C_{uc}CRF_{uc} \times (1 + k_{ouc} + k_{duc}) \quad (1)$$

$$CRF = \frac{r(1+r)^y}{(1+r)^y - 1} \quad (2)$$

In the formula,  $E_{ba}$  and  $E_{uc}$  are capacities of battery pack and super capacitor in the hybrid energy storage system;  $C_{ba}$  and  $C_{uc}$  separately are the price of per unit capacity of battery and super capacitor; Capital recovery factor  $CRF$  is used to convert total cost to annual cost;  $r$  is discount rate,  $y$  is the life cycle of the

energy storage system;  $k_{oba}$ ,  $k_{mba}$  and  $k_{dba}$  separately are the factors of battery operation, maintenance and disposal cost;  $k_{ouc}$  and  $k_{duc}$  separately are the factors of super capacitor operation and processing cost.

The expression of annual revenue of energy storage system  $I$  is:

$$I = e(E_{HESS} + E_L) \cdot R \quad (3)$$

$$E_L = \sum_{t=1}^T \min\{P_L(t), P_{PV}(t)\} \Delta t \quad (4)$$

In the formula,  $e$  is electricity price,  $E_{HESS}$  and  $E_L$  separately are the power provided for load by energy storage system and photovoltaic system.  $P_L(t)$  is the load power at the time of  $t$ ,  $P_{PV}(t)$  is the photovoltaic power at the time of  $t$ .  $R$  is similar day, consider factors as weather, take the value  $R = 260$ .

### 3.2 Optimize the Target

Hybrid energy storage system can promote the consumption of photovoltaic power generation and realize the value-added of photovoltaic power generation. Therefore, under the premise of meeting the reliable operation of the system, this paper takes maximizing annual net profit of charging station  $C_{net}$ , photovoltaic consumption rate  $S_{PV}$  as the goal to establish the multi-objective capacity optimization configuration model.

$$f_1 = \max(C_{net}) = C_0 R - C_{HESS} \quad (5)$$

$$f_2 = \max(S_{PV}) = \frac{E_L + E_{HESS}}{\sum_{t=1}^T P_{PV}(t)} \quad (6)$$

### 3.3 Restrictions

#### (1) Restriction of Hybrid Energy Storage System

To ensure the normal operation of the hybrid energy storage system and extend the life of the energy storage system, according to the operation strategy of the energy storage system, in the energy storage system, the capacity and power of the energy storage system should meet the restriction formula(7)~(13).

$$E_{ba}(t + \Delta t) = E_{ba}(t) + \varepsilon_{bac} P_{bac}(t) \Delta t \cdot \eta_{bac} - (1 - \varepsilon_{bac}) P_{bac}(t) \Delta t / \eta_{bad} \quad (7)$$

$$E_{uc}(t + \Delta t) = E_{uc}(t) + \varepsilon_{ucc} P_{ucc}(t) \Delta t \cdot \eta_{ucc} - (1 - \varepsilon_{ucc}) P_{ucc}(t) \Delta t / \eta_{ucd} \quad (8)$$

$$E_{bamin} \leq E_{ba}(t) \leq E_{bamax} \quad (9)$$

$$E_{ucmin} \leq E_{uc}(t) \leq E_{ucmax} \quad (10)$$

$$P_{ba}(t) = P_{ba} \quad (11)$$

$$P_{uc}(t) \leq P_{ucmax} \quad (12)$$

$$D_{OD} \leq 0.8 \quad (13)$$

In the formula,  $E_{ba}(t), P_{bac}(t), P_{badc}, \eta_{bac}, \eta_{bad}$  separately are battery capacity, charge / discharge power and charge / discharge efficiency at a certain moment;  $E_{uc}(t), P_{ucc}(t), P_{ucdc}(t), \eta_{ucc}, \eta_{ucd}$  separately super capacitor capacity, charge/discharge power and charge/discharge efficiency at a certain moment;  $E_{bamin}$  is the minimum remaining capacity of battery pack, the maximum capacity of battery pack  $E_{bamax}$  is its rated capacity.  $E_{ucmin}, E_{bamax}$  is the upper and lower limits of the energy storage of the super capacitor.

#### 4. Solving Process

##### 4.1 Multi-objective Quantum Particle Swarm Algorithm

Particle swarm optimization (PSO) is the bionic algorithm inspired by the flock foraging activity from Kennedy and Eberhart. [7] Sun[8] A particle swarm optimization algorithm with quantum behavior characteristics is proposed, the global optimization capability of quantum particle swarm algorithm is far superior to the standard PSO, algorithm has not been quickly updated, only displacement update, its displacement update equation is as shown in formula(14).

$$\left\{ \begin{array}{l} x_{i+1} = p_i \pm \beta |m_{best} - x_i| \ln(1/u) \\ p_i = (\varphi_1 p_{bi} + \varphi_2 p_{gi}) / (\varphi_1 + \varphi_2) \\ m_{best} = \frac{1}{N} \sum_{i=1}^N p_{bi} \end{array} \right. \quad (14)$$

MOPSO mainly uses the dominance relationship between particles to find the optimal historical solution of particles and update the non-inferior solution set by combining Pareto sorting mechanism, and choose the global optimal solution based on the crowded distance to solve the multi-objective problem. [9] In this paper, QMOPSO is used to calculate by combining AQPSO and MOPSO.

The steps of QMOPSO are as below:

- (1) Initialize the population, make the external file set an empty set.
- (2) Calculate the target vector corresponding to each particle, set as  $p_{bi}$ , Generate non-dominated solutions based on Pareto dominance and store them in external files;
- (3) Choose global leader  $p_{gi}$  from external archives for each particle according to the crowded distance.
- (4) Update the particle position according to formula(14), calculate the target vector of the updated particles. If the target vector of the updated particle can dominate the  $p_{bi}$  of the previous generation of particles, then update  $p_{bi}$ .
- (5) Update external files;

(6) If the maximum number of iterations is reached, then turn to the next step, or turn to step (3);

(7) Output the Pareto optimal solution in the external file as the final solution.

#### 4.2 Improved TOPSIS

The final result of particle swarm optimization (PSO) for multi-objective optimization problem is a set of Pareto optimal solution set, decision makers need to select the best compromise solution from the Pareto optimal solution set, the essence is a multi-attribute decision problem. TOPSIS algorithm is a decision-making method for multi-attribute decision analysis. By calculating the distance between each scheme and the best scheme and the worst scheme, the relative closeness of each scheme to the best scheme is obtained as a basis for evaluating the advantages and disadvantages. The feasible solution which is the closest solution to the positive ideal solution, and the farthest solution to the negative ideal solution is the optimal solution. In the multi-objective optimization problems, the positive ideal solution is the solution that achieves the optimal results for each objective; the negative ideal solution is the worst solution for each goal. The steps to use the improved TOPSIS algorithm to select the best compromise solution for a multi-objective optimization problem from the Pareto optimal front are as below:

(1) Structure of Decision Matrix

There are  $m$  objective functions in the multi-objective optimization,  $n$  non-inferior solutions, A decision matrix  $Y = (f(x_{ij}))_{n \times m}$  ( $i = 1, 2, \dots, n; j = 1, 2, \dots, m$ ) is composed of the objective function of  $n$  to the inferior solution.

(2) Since the dimension and range of decision variables are different, this paper uses the vector normalization method to normalize the decision matrix  $Y$  for matrix  $Z = (z_{ij})_{n \times m}$  ( $i = 1, 2, \dots, n; j = 1, 2, \dots, m$ ):

For positive targets(The bigger, the better, the transformation formula is:

$$z_{ij} = \frac{f(x_{ij})}{\sqrt{\sum_{i=1}^n f(x_{ij})^2}}$$

For negative targets(The smaller, the better, the transformation formula is:

$$z_{ij} = \frac{1/f(x_{ij})}{\sqrt{\sum_{i=1}^n 1/f(x_{ij})^2}}$$

(3) Determine target weights, judged and determined by decision makers based on experience and expectations.

(4) Determine positive ideal solution  $z^+$  and negative ideal solution  $z^-$ , that is, the best and worst solutions for each goal:

$$z^+ = \{z_1^+, z_2^+ \dots z_m^+\} = \{\max_j z_{ij}\}$$

$$z^- = \{z_1^-, z_2^- \dots z_m^-\} = \{\min_j z_{ij}\}$$

(5) Calculate the distance from  $z_{ij}$  positive ideal solution and negative ideal solution  $S_i^+$  and  $S_i^-$ , further count the relative proximity from  $z_{ij}$  to the ideal solution, calculate  $R_i$

$$R_i^+ = \sqrt{\sum_{j=1}^m (z_{ij} - z_j^+)^2}$$

$$R_i^- = \sqrt{\sum_{j=1}^m (z_{ij} - z_j^-)^2}$$

$$R_i = \frac{R_i^-}{R_i^+ + R_i^-}$$

In the formula: The bigger the value of  $R_i$  in the scheme, the closer to the ideal point; the scheme with the smallest  $R_i$  is the best scheme.

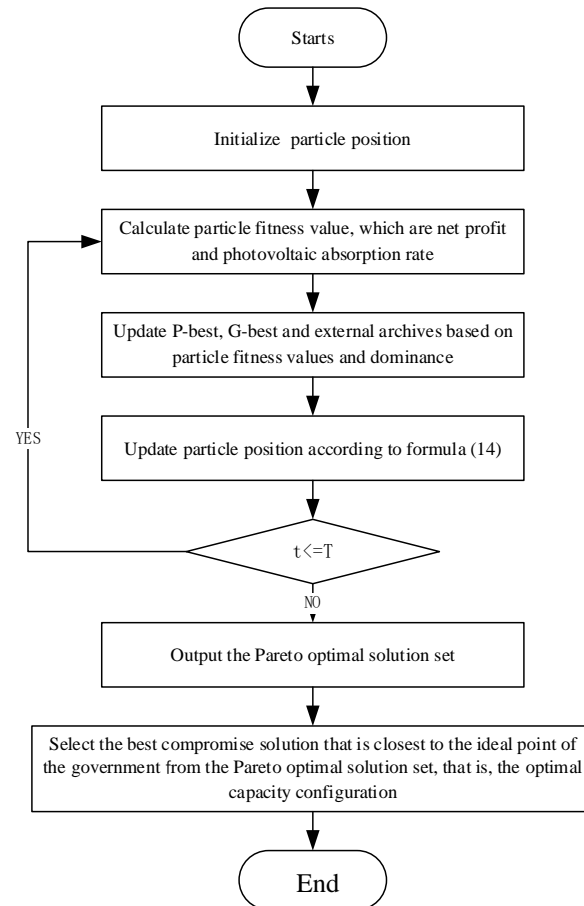

Fig.2 Flow of solving process

### 4.3 Solving Process for Optimal Allocation of Hybrid Energy Storage

Figure 2 is the solving process of QMOPSO and TOPSIS algorithms for hybrid energy storage capacity optimization models for photovoltaic charging stations.

## 5. Simulations and Analysis

### 5.1 Setting of Simulation Parameters

Take one highway fast charging station as the research object, the photovoltaic installed capacity is 800kW, use the local daily photovoltaic output data, which is



shown as in Figure 3. Considering the development of battery fast charging technology, the typical DC fast charging power of a single electric vehicle is about 120kw, and the average capacity of the power battery is 30kWh. Assume that the number of daily charging cars is 400, Initial state of charge of electric vehicle satisfies the normal distribution of  $N(0.3, 0.1^2)$ , the end state of charge is 1. EV charging at charging station is similar to the charging rule of small vehicles at gas station. According to the statistics of the daily arrivals of traditional gas stations, it can be known that the number of electric vehicles arriving per hour, and the charging load demand obtained through Monte Carlo simulation is shown in Figure 3.

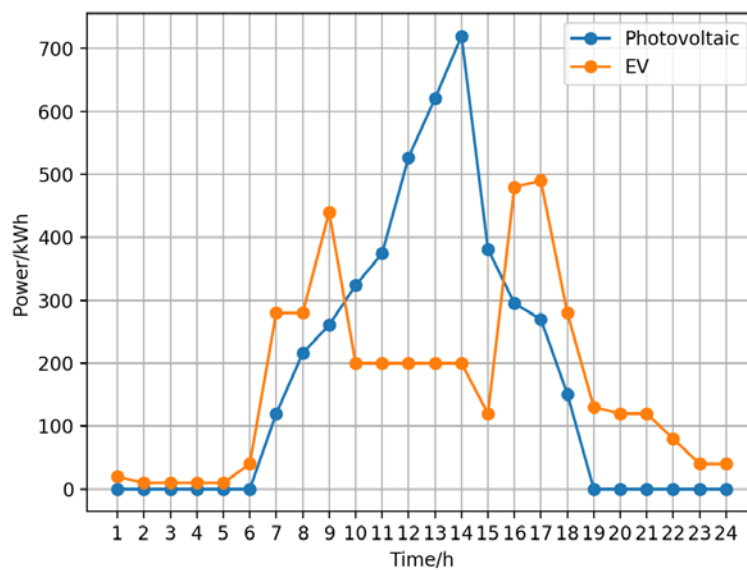

Fig.3 Photovoltaic output and charging load power curve

### 5.2 Analysis of Optimal Configuration of Hybrid Energy Storage

Program and solve QMOPSO algorithm, TOPSIS algorithm and optimization model with Pycharm software, the related parameters of battery and super capacitor are shown in the table. The program sets the number of population to 200 and the maximum number of iterations to 100. The creation coefficient  $\beta$  decreases linearly with the number of iterations from 1.0 to 0.5. The procedure is repeated 30 times, and the non-dominated solution set obtained from 25 calculations is consistent, the algorithm has quite good stability. The process of exploring Pareto solutions is show in Fig 4, the optimization result is a set of Pareto optimal solutions. In practical applications, different weights can be set for the two goals according to the development positioning of the target city and the consideration of various factors.

TOPSIS method is used to select optimal configuration schemes.

*Table 1. Specifications of batteries and supercapacitors*

Battery		Supercapacitor	
Rated Capacity (Ah)	100	Capacitance (F)	3500
Rated voltage (V)	1.2	Voltage range (V)	[0.8,2.7]
DOD	0.8	Maximum current (A)	1500
Cycles of life	4500	Cycles of life	150000
Charging efficiency	0.8	Charging efficiency	0.98
Discharging efficiency	0.9	Discharging efficiency	0.98
Operation cost coefficient	0.1	Operation cost coefficient	0.01
Maintenance cost coefficient	0.02	Maintenance cost coefficient	0
Disposal cost coefficient	0.08	Disposal cost coefficient	0.04
Unit price (¥)	2400	Unit price (¥)	350

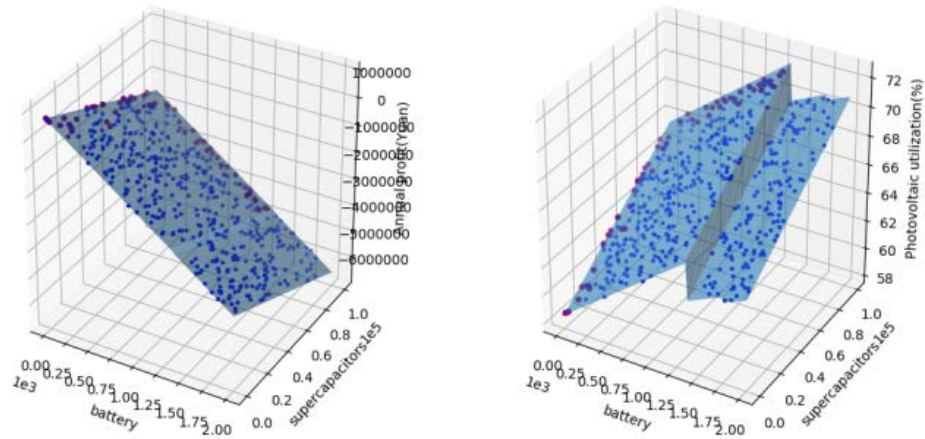

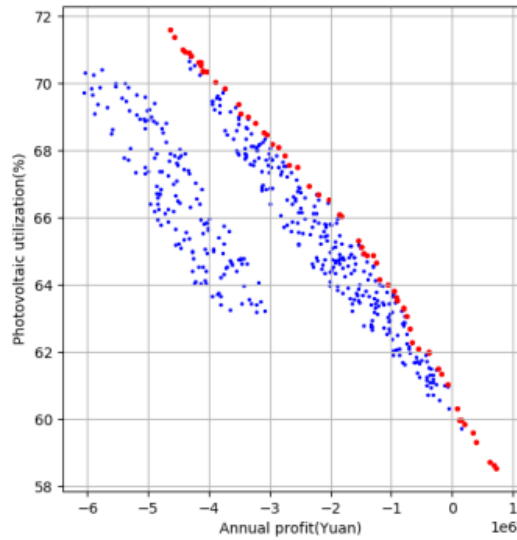

Fig. 4 The process of exploring Pareto solutions

This case analysis shows the superiority of the hybrid energy storage system. Simulation of the two scenarios of hybrid energy storage and single battery energy storage has been carried out. Set the target weight in the TOPSIS method to(0.5,0.5), and get optimized configuration schemes for two scenarios, the results are shown as in Figure 5.

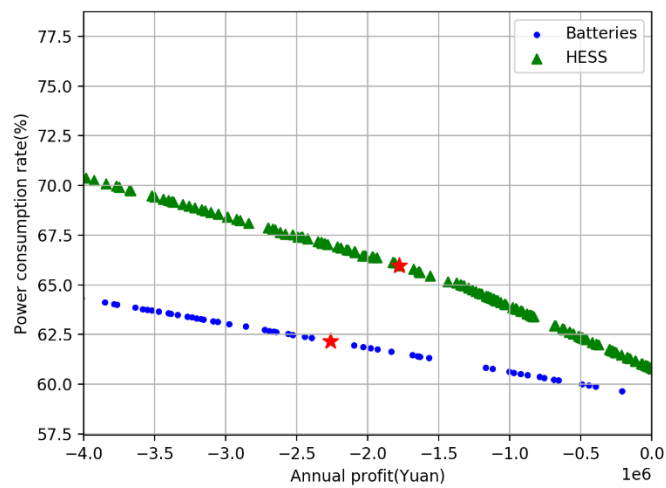

Fig.5 The Pareto solutions and The optimization result of two scenarios

Results show that the optimal solution for hybrid energy storage is better than the optimal solution for battery energy storage, and has improved photovoltaic utilization and revenue. At the same photovoltaic consumption rate, the benefits of hybrid energy storage are higher than those of battery energy storage, it is because the battery is frequently charged and discharged, which affect the working life. Super capacitors with high power density and long cycle life are added to the hybrid energy storage to bear the fluctuating power with large frequency. The battery is only charged and discharged at the rated power, which effectively improves the battery's working life and the economy of the entire life cycle of the system.

### 5.3 Analysis of Algorithm Superiority

To verify the superiority of multi-objective quantum group algorithm, MOPSO and improved QMOPSO are used to solve the examples respectively in this paper, the results obtained by the two algorithms are shown as in Figure 6.

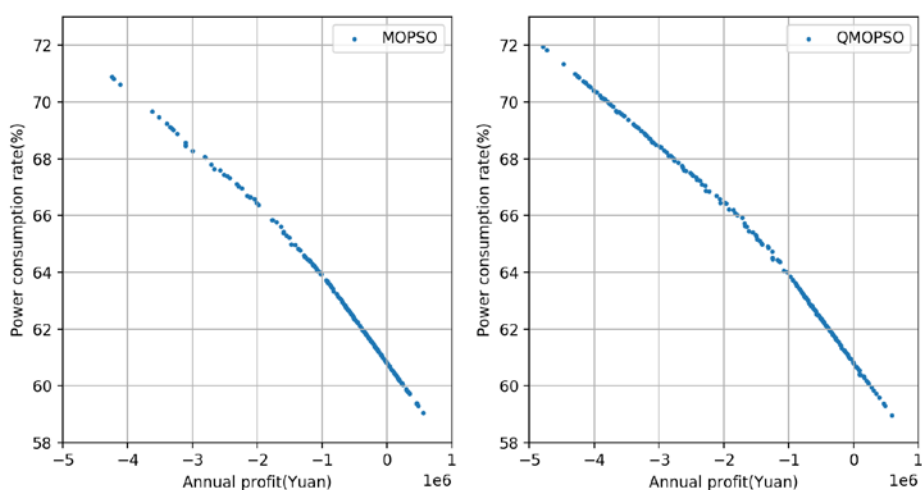

Fig.6 The Pareto solutions of MOPSO and QMOPSO

By comparing the Pareto solution distribution diagrams in the figure, it can be intuitively seen that the optimized solution set using the improved QMOPSO algorithm proposed in this paper has better diversity, and the solution distribution is more uniform. Therefore, the improved algorithm has better global optimization ability, and it is not easy to fall into the local optimal solution. So, the improved QMOPSO algorithm can be better applied to the hybrid energy storage capacity configuration of the independent photovoltaic power plants.

## 6. Conclusion

Aim at the problem of hybrid energy storage capacity allocation for photovoltaic power stations.(1)In this paper, the introduction of super capacitors in the energy storage configuration of independent photovoltaic power stations effectively improves the working life of the battery and the utilization rate of photovoltaic power generation.(2)This paper combines the QMOPSO algorithm and the TOPSIS algorithm to optimize the energy storage configuration, which can not only improve the utilization rate of photovoltaic power generation, but also give full play to the maximum benefits of the energy storage access system, so that makes the system take into account both energy saving and emission reduction and the highest efficiency. (3) Improve on the basis of multi-objective quantum group algorithm, the value of the inertia weight is guided according to the gap between the particle and the contemporary optimal particle. Introduce NSGAI algorithm for fast non-dominated sorting, elite retention strategy, and dynamic congestion, and then select the optimal solution with TOPSIS. Compared with the conventional multi-objective particle swarm algorithm optimization, it is verified that the proposed algorithm has better convergence and accuracy than the traditional algorithm. It improves the problem of premature particle swarm algorithm and easy to fall into local optimum, which makes the distribution of Pareto solution more uniform. It ensures population diversity, greatly improves the search performance of the algorithm, and has reference significance in solving the hybrid energy storage capacity configuration.

## Acknowledgements

Funding: This research was funded by National Natural Science Foundation of China (Grant number: 71771085), Scientific Research Project of Universities in Inner Mongolia (Grant number: NJZC17415) and Research Project of Ordos Institute of Technology (Grant number: KYYB2017013).

## References

- [1] Hassan H. Eldeeb, Samy Faddel, Osama A. Mohammed. Multi-Objective Optimization Technique for the Operation of Grid tied PV Powered EV Charging Station. *Electric Power Systems Research* 2018; 164:201-211. doi.org/10.1016/j.epsr.2018.08.004.
- [2] Pinak J. Tulpule, Vincenzo Marano, Stephen Yurkovich, Giorgio Rizzoni. Economic and environmental impacts of a PV powered workplace parking garage charging station.*Applied Energy* 2013; 108:323-332. doi.org/10.1016/j.apenergy.2013.02.068.
- [3] Chen Zheng, Xiao Xiangning, Lu Xinyi, Liu Nian, Zhang Jianhua. Multi-Objective Optimization for capacity configuration of PV-Based Electric Vehicle Charging Stations. *Transaction of China Electrotechnical society* 2013; 28:238-247.

- [4] Lu jinling, Yang Yue, Wang yang, He tongxiang. Copula-based capacity configuration of energy storage system for a PV-assisted electric vehicles charging station. *Acta Energiæ Solaris Sinica* 2016; 37:780-786.
- [5] Vinit Kumar, Villuri Ravi Teja, Mukesh Singh, S. Mishra. Energetic, economic and environmental viability of off-grid PV-BESS for charging electric vehicles: Case study of Spain. *Sustainable Cities and Society* 2018; 37: 519-529. doi.org/10.1016/j.scs.2017.12.009.
- [6] Zhixiong Luo, Fang He, Xi Lin, Jianjun Wu, Meng Li. Joint deployment of charging stations and photovoltaic power plants for electric vehicles, *Transportation Research Part D: Transport and Environment* 2020; 79:1361-9209.doi.org/10.1016/j.trd.2020.102247.
- [7] Alan R. Kennedy, Ronald J. Cross, Kenneth W. Muir. Preparation and crystal structure of trans-[NiBr{C<sub>6</sub>H<sub>3</sub>-2,6-(CH<sub>2</sub>PCy<sub>2</sub>)<sub>2</sub>)]. *Inorganica Chimica Acta* 1995;231:195-200.doi.org/10.1016/0020-1693(94)04321-L.
- [8] Sun J, Feng Bin, Xu wenbo. A global search strategy of quantum-behaved particle swarm optimization. *IEEE Conference on cybernetics and Intelligent Systems*. Piscataway, NJ: IEEE Press 2004:111-116.
- [9] Li Xueqiang, Liu Hailin. New Evolutionary Algorithm for complicated Multiobjecetive Optimization. *Journal of system Simulation* 2011; 23:1860-1865.
- [8] Li Yangyang, Xiang Rongrong, Jiao Lingcheng, et al. An improved cooperative quantum-based particle swarm optimization. *Soft comput* 2012; 16:1061-1069.