

Research on Simulated Apparatus for Physics Velocity Experiments

Chenwei Li¹, Jinguang Zhu², Yiwei Wang², Defeng Zhang²

¹Affiliated High School of Inner Mongolia Normal University, Hohhot, Inner Mongolia, 010020, China

²Second High School of Hohhot, Hohhot 010020, Inner Mongolia, China

Abstract: Experiments play a crucial role in high school physics education, providing a solid foundation for establishing concepts and discovering laws in physics. Experimental teaching is an essential component of the physics curriculum, as it aids students in understanding fundamental principles, developing basic skills, and cultivating scientific thinking. Relying solely on textbook knowledge and teacher lectures is insufficient for students to thoroughly grasp and comprehend physics concepts. By incorporating physics experiments, students can effectively integrate theoretical knowledge with practical exploration, facilitating the transformation of textbook knowledge into personal understanding. This article presents a specific simulated apparatus for high school physics velocity experiments, aiming to improve the accuracy and convenience of simulating physics velocity experiments through equipment enhancements.

Keywords: Physics; Velocity Experiment; Simulated Apparatus

1. Introduction

With the continuous advancement of the new curriculum reform, high school physics education has increasingly emphasized demonstrations and group experiments. High school physics involves numerous experiments with rich content, significantly contributing to the development of physics and physics education. Conducting physics demonstration experiments in the classroom helps students master the methods of exploring physics experiments and provides deeper insights into the essence of the physical laws being studied. This fosters students' interest in learning physics, transforming the previous passive teaching approach into an active learning mode, thereby enhancing the effectiveness of high school physics classroom teaching. With the rapid development of science and technology, physics experimental equipment and experimental plans have also been optimized and adjusted, making high school physics classrooms more efficient. This article introduces a simulated apparatus for physics velocity experiments, with the aim of infusing the physics classroom with more vitality and making it engaging and enjoyable through equipment enhancements and experimental plan optimization.

2. Problem Statement

Physics is a discipline based on experimentation, and classroom teaching heavily relies on practical experiments. Through experimentation, students can correctly observe the key characteristics of phenomena and obtain accurate representations, thereby enhancing their understanding of textbook content and mastering the knowledge they learn. One crucial aspect of physics experiments is velocity experiments, particularly those related to the relationship between velocity and mass. Existing experimental apparatus for velocity simulation typically employ a dot timer and a track for sliding objects. However, these existing devices lack convenient adjustment of the track's angle, which limits the diversity of experimental data. Additionally, placing the current apparatus directly at the edge of the experimental table can compromise its overall stability, especially when the traction force applied to the small car is significant.

3. Development of the Experimental Apparatus

3.1. Functional Design of the Experimental Apparatus

The purpose of this utility model is to provide a physics experimental apparatus for simulating velocity, aiming to address the issues identified in the prior art, such as the inconvenience of adjusting the track's angle, which affects the variety of experimental data, and the direct placement of the current apparatus at the edge of the experimental table, leading to stability issues.

Given the inconveniences in the existing technology regarding track angle adjustment, affecting the diversity of experimental data, and the stability problems associated with direct placement at the edge of the experimental table, the inventors conducted research to develop a physics experimental apparatus for simulating velocity. This apparatus involves using a U-shaped plate to fit around the edge of the experimental table, and then turning the knob to rotate a threaded rod, which clamps the bottom of the plate against the edge of the table. This allows for convenient positioning and fixation of the baseplate, facilitating its use. By rotating the handle, the threaded rod drives a driving block to move away from the axis direction along the baseplate, lifting the sliding rail at one end away from the axis. The sliding rail can be adjusted multiple times to different incline angles to obtain various velocity measurement data. The extension axis synchronously rotates with the sliding rail's rotation center, driving the pointer to rotate accordingly. The angle markings inside the marking slot facilitate quick adjustment of the sliding rail's incline angle. The overall device is easy to store and adjust, effectively addressing the aforementioned deficiencies. [1]

3.2. Development of the Experimental Apparatus

3.2.1. Working Principle and Structure

The physics experimental apparatus for simulating velocity comprises a baseplate with a rotating shaft mounted at one end. A sliding rail is fitted on the rotating shaft, and an elevating component is installed between the sliding rail and the baseplate to adjust the incline angle of the sliding rail away from the rotating shaft. A positioning component is installed on one side of the baseplate to secure it in place. Near the rotating shaft, the sliding rail features wire holes, while the baseplate's end close to the wire holes is equipped with a wire mechanism for fixation.

3.2.2. Components of the Experimental Apparatus

The experimental apparatus includes the following components:(1) Elevating Component: It consists of a flipping frame connected to the baseplate for rotational movement, and the bottom of the flipping frame is connected to a threaded reciprocating mechanism.(2) Threaded Reciprocating Mechanism: This mechanism includes a column fixed within the baseplate, with a threaded rod attached to it. One end of the threaded rod has a rotating handle, and the other end has a threaded block that fits tightly against the baseplate. The top of the threaded block is connected to the bottom of the flipping frame.(3) Positioning Component: This component includes a U-shaped plate connected to the side of the baseplate and an abutting mechanism mounted at the top of the U-shaped plate.(4) Abutting Mechanism: It involves a threaded rod inserted into the top of the U-shaped plate, with a rotating knob fixed at its top and an abutting plate rotating on its bottom.(5) U-shaped Plate, Slider, and Baseplate: The U-shaped plate has a slider fixed on one side, and the baseplate features a side groove suitable for the slider's adaptation. The end face of the slider and the side groove are T-shaped, and a positioning bolt is installed on one side of the slider.(6) Wire Mechanism: It comprises an extension frame fixed to one side of the baseplate and a wire wheel mounted at the top of the extension frame.(7) Buffer Component: This component includes a guiding rod inserted into the sliding rail, with a buffer block fixed at one end and a convex block fixed at the other end. The guiding rod has a spring near the buffer block, and the outer wall of the guiding rod forms a damping sliding fit with the sliding rail.(8) Marking Component: It consists of a marking slot opened on one side of the baseplate near the end of the rotating shaft. A extending shaft, connected to the end of the rotating shaft, is pivotally inserted into the marking slot. A pointer is fixed on one side of the extending shaft, and circular angle markings are provided within the marking slot. [2]

4. Implementation Method

4.1. Device Movement Principles

(1) At one end of the baseplate, a rotating shaft is installed, and a sliding rail is mounted on the rotating shaft. The sliding rail is equipped with an elevating component that adjusts the incline angle of the sliding rail away from the rotating shaft. A positioning component is installed on one side of the baseplate to secure it in place. Near the rotating shaft, the sliding rail features wire holes, and a wire mechanism is fixed at the end of the baseplate close to the wire holes. [3]

To begin the experiment, the apparatus is placed along the edge of the experimental table, and the positioning component is used to secure the baseplate at the edge of the table, making it convenient for use. Then, the dot timer is installed at one end of the sliding rail, and a rope with attached weights is connected to the test car. The test car is connected to the paper tape passing through the dot timer. By releasing the weights, the car moves along the sliding rail, facilitating velocity measurements. The elevating component is used to adjust the sliding rail to different incline angles, obtaining various velocity measurements. The overall device is easy to store and adjust.

(2) The elevating component includes a flipping frame connected to the baseplate for rotational movement. The bottom of the flipping frame is connected to a threaded reciprocating mechanism. The threaded reciprocating mechanism consists of a column fixed within the baseplate, with a threaded rod attached. One end of the threaded rod has a rotating handle, and the other end has a threaded block that fits tightly against the baseplate. The top of the threaded block is connected to the bottom of the flipping frame. By rotating the handle, the threaded rod drives the threaded block to move away from the rotating shaft along the baseplate, causing the flipping frame to lift one end of the sliding rail away from the rotating shaft and achieve the purpose of adjusting the incline angle of the sliding rail.

(3) The positioning component includes a U-shaped plate connected to the side of the baseplate and an abutting mechanism mounted at the top of the U-shaped plate. The abutting mechanism comprises a threaded rod inserted into the top of the U-shaped plate, with a rotating knob fixed at its top and an abutting plate rotating on its bottom. The U-shaped plate is fixed with a slider on one side, and the baseplate has a side groove suitable for the slider's adaptation. The end face of the slider and the side groove are T-shaped, and a positioning bolt is installed on one side of the slider. The U-shaped plate can be fitted around the edge of the experimental table. By turning the knob, the threaded rod rotates, and the abutting plate clamps the U-shaped plate against the edge of the table, facilitating the positioning and fixation of the baseplate, thereby preventing the apparatus from shaking during velocity testing. [4]

(4) The wire mechanism includes an extension frame fixed to one side of the baseplate, with a wire wheel mounted at the top of the extension frame. The wire wheel guides the testing rope to prevent shaking.

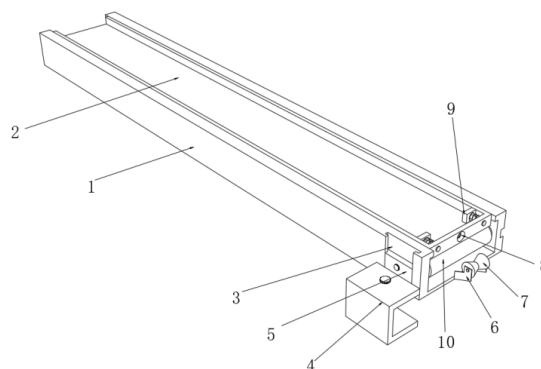

Figure 1: Schematic Diagram of the Experimental Apparatus

(5) The buffer component: Two symmetric buffer components are set at one end of the sliding rail close to the rotating shaft. The buffer components consist of guiding rods inserted into the sliding rail, with buffer blocks fixed at one end and convex blocks fixed at the other end. The guiding rods have

springs near the buffer blocks, and the outer wall of the guiding rods forms a damping sliding fit with the sliding rail. The buffer blocks, together with the guiding rods' damping and the spring's elasticity, perform buffer and braking functions on the car moving to the end of the sliding rail, preventing violent collisions and buffering the initial impact of the car. [5-6] See Figure 1 below for specific details.

The specific components in Figure 1 are as follows: 1. Baseboard; 2. Slide rail; 3. Side groove; 4. Positioning component; 5. Slider; 6. Extension frame; 7. Wire wheel; 8. Wire hole; 9. Buffer component; 10. Axis

4.2. Operation Procedure

In this study, a physics experimental apparatus for simulating velocity was designed. The apparatus utilizes a U-shaped plate to be fitted around the edge of the experimental table, and by turning the knob, the threaded rod is rotated to clamp the baseplate against the edge of the table, facilitating its positioning and fixation for ease of use. By turning the handle, the threaded rod drives the driving block to move away from the rotating shaft along the baseplate, causing the flipping frame to lift one end of the sliding rail away from the rotating shaft. Multiple adjustments of the sliding rail are made to different incline angles, obtaining various velocity measurement data. The extension shaft synchronously rotates with the turning base point of the sliding rail, driving the pointer to rotate synchronously, and aligning with the angle marks in the marking slot to quickly adjust the incline angle of the sliding rail, making the entire device easy to store and adjust.

To begin the operation, the apparatus is placed along the edge of the experimental table, with the U-shaped plate positioned at the edge of the table. Then, by turning the knob, the threaded rod is rotated to clamp the baseplate against the edge of the table, facilitating its positioning and fixation for ease of use. The dot timer is then installed at one end of the sliding rail, and the rope with attached weights is connected to the test car. The test car is connected to the paper tape passing through the dot timer. By releasing the weights, the test car moves along the sliding rail for velocity measurement. The buffer block is employed to dampen and buffer the initial impact of the car as it reaches the end of the sliding rail, preventing violent collisions. The handle is then turned to drive the threaded rod, causing the driving block to move away from the rotating shaft along the baseplate.[7] The flipping frame lifts one end of the sliding rail away from the rotating shaft. Multiple adjustments of the sliding rail to different incline angles are made, obtaining various velocity measurement data. The extension shaft synchronously rotates with the turning base point of the sliding rail, driving the pointer to rotate synchronously. The angle marks in the marking slot are used to quickly adjust the incline angle of the sliding rail. The entire apparatus is easy to store and adjust.

5. Conclusion

In high school physics teaching, experiments play a crucial role in helping students understand the key features of phenomena and grasp the knowledge taught in textbooks. Among various experiments, velocity-related experiments are of great importance. However, the current velocity simulation devices mainly rely on dot timers and sliding tracks. These devices have limitations, such as the inconvenience of adjusting the track angle, which affects the diversity of experimental data.

To address these shortcomings, this article proposes a conceptual physics velocity simulation apparatus. It involves using a U-shaped plate to fit around the edge of the experimental table, and with the aid of corresponding knobs, the threaded rod can be rotated to easily position and fix the baseplate. This setup allows for multiple adjustments of the sliding rail to different incline angles, thereby obtaining diverse velocity measurement data. The apparatus has the advantages of easy storage and adjustability, effectively addressing the current deficiencies in physics velocity experiment devices. The goal is to contribute to efficient and exciting physics classroom experiences.

References

- [1] Lin, T., Song, H., Sun, Y., et al. (2021). *Development of High-Temperature and High-Pressure Visualization Physics Simulation Apparatus. Laboratory Research and Exploration*, 40(07), 76-79.
- [2] Chen, S. S. (2021). *Improvement and Application of the "Measurement of Reaction Rate" Experimental Apparatus. High School Biology Teaching*, (19), 61-63.
- [3] Hong, H. B., Song, L. Y., Feng, Y. Q., et al. (2021). *Development of High School Physics*

- Experimental Apparatus Based on STEM Concept. Chinese Physics Bulletin, (06), 93-96.*
- [4] Zang, Z. Y., Jing, X. B., Long, Q. H., et al. (2018). *Exploration of Mechanical Design for Physics Experimental Apparatus. China New Technology and New Products, (18), 92-93.*
- [5] Wang, X. Q., Dai, L. N. (2015). *Truly Optimizing Physics Experiments: Achieving Efficient Physics Classroom through the Improvement of Newton's Second Law Experiment Apparatus. Reference for High School Physics Teaching, 44(23), 58-59.*
- [6] Yang, L., Ren, X. H., Qi, Y. G., et al. (2010). *Design and Application of Multi-functional Structural Physics Simulation Apparatus. Journal of China University of Petroleum (Edition of Natural Science), 34(05), 152-158.*
- [7] Zhang, X. K. (2008). *Analysis of High School Physics Experimental Apparatus and Experimental Methods Selection. Curriculum, Textbooks, and Teaching Research (Education Research Edition), (05), 44-45.*