

# A Novel UAV Integrated with Fixed-Wings Aircrafts and Rotorcrafts

Zhixing Zhang<sup>1,a,#</sup>, Haoran Shi<sup>1,b,#</sup>, Lilue Wen<sup>1,c,#</sup>, Xiaoqing Zhu<sup>2,d,\*</sup>

<sup>1</sup>Beijing 21st Century International School, Beijing, China

<sup>2</sup>Faculty of Information Technology, Beijing University of Technology, Beijing, China

<sup>a</sup>Zhangzhixing1106@hotmail.com, <sup>b</sup>shihaoran105@163.com, <sup>c</sup>wenlilue@gmail.com,

<sup>d</sup>553455117@qq.com

<sup>#</sup>Co-first author

<sup>\*</sup>Corresponding author

**Abstract:** In recent years, UAVs have been widely used in various fields. According to our team's preliminary research, the current UAVs can be generally divided into fixed wing and rotor wing. These two categories of UAVs have their own advantages and disadvantages. Modern UAVs have some problems, such as fixed wing needs runway to take off, poor mobility, rotor wing UAV has low energy efficiency, although it has the ability of vertical take-off and landing, the load is low. Since the Internet had promoted the transportation of cargoes, it seems pretty urgent to deal with issues of sending goods to desolate locations like remote mountain areas or deserts. This paper discusses the possibility of combining fixed-wing and rotorcraft UAVs. The design of this paper is to follow the model of the fixed-wing aircraft, and the wing is equipped with upward oars to provide upward lift. In this way we can have both the speed of a fixed-wing UAV vertical take-off and landing capability of a rotorcraft UAV. This makes the UAV more energy efficient and has higher endurance and speed with the same load. The payload is higher for the same endurance.

**Keywords:** fixed-wing aircraft, rotorcrafts, express delivery

## 1. Introduction

In today's world, drones have become an indispensable tool in many fields [1-5]. Examples include video capture, drone delivery, post-disaster search and rescue, highway surveillance, and environmental monitoring.

In fact, policies on UAVs vary from country to country. Some countries consider UAVs as sensitive equipment. For example, Jordan often investigates people carrying UAVs on the grounds of endangering national security. According to the survey, 73% of countries in the world have a policy of flying drones without reporting, such as most countries in Europe [6]. Five percent of countries have a policy of requiring registration, which allows them to fly anywhere except in no-fly zones. The policy of 12% countries also requires registration, but it is difficult to register [7]. About 10% of the world's countries are completely banned from flying, such as Russia and Thailand.

Drones are so popular with people in most countries of the world because they have many advantages that manned aircraft do not have. Fixed-wing UAVs have the advantages of high speed, large load and high energy efficiency ratio [8]. Rotorcraft has the advantage of being portable and not needing a runway [9].

Modern UAVs also have some unavoidable shortcomings, which results in UAVs still cannot replace many tools. For example, fixed-wing drones need a long runway to take off and have low mobility, which makes it impossible to fly inside cities. Rotor UAVs have the disadvantages of low energy efficiency, low endurance and low load [10].

Unmanned Aerial Vehicle (UAV) widely involved abundant constructions, we can separate UAVs into three different classifications according to their mode of fly: fixed wings, rotorcrafts, flapping wings [11]. Fixed wings, which can be seen in long-distance airways, use unmovable wings with horizontal air engine to produce moving force; rotorcrafts, which is really famous for civil use, have several rotating wings above the body part of the UAV in order to give force of both vertical and horizontal (Fig. 1)[12]; flapping wings, which is related to bionics, flap its wings so that it can fly, just likes dragonflies and birds

(Fig. 2) [13-17].



*Figure 1: Rotorcraft*



*Figure 2: Flapping wings UVA*

Since the Internet had promoted the transportation of cargoes, it seems pretty urgent to deal with issues of sending goods to desolate locations [18-20]. On June 8th, 2016, JD began to use UAVs, especially rotorcrafts, to help send goods to remote mountainous region, but because of under endurance, such UAVs cannot carry heavy cargoes or fly a long distance. Accordingly, we want to create a new type of UAV that can keep both mobility and long-lasting ability. This type of UAV has both features of fixed wings and rotor wings in order to move high-efficiently and long-lasting.

## **2. UAV Design**

These are the views of the UAV from different angles (Fig. 3, Fig. 4, Fig. 5 and Fig. 6). This UAV is a combination of fixed-wing UAV and rotor-wing UAV. There are two brackets on the fuselage, and there is a propeller at both ends of each bracket to ensure the lifting force of the UAV. Secondly, there is a large propeller at the head of the UAV, which ensures the forward power. Creo is used to model my UAV. Four small spiral wings and one large spiral wing are movable. The UAV has a tail at the end, which can ensure that the UAV can maintain balance during flight. There is no wheel set at the bottom of the UAV, so it is necessary to throw the UAV from a high place by hand, so that it can glide with the help of the lift of four small propellers and the lift of the wings.

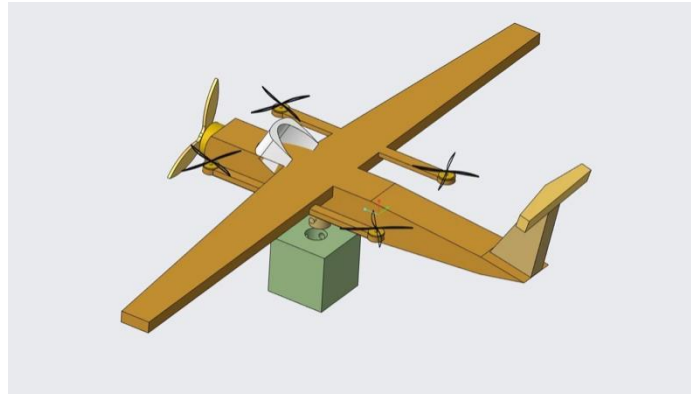

Figure 3: Isometric view

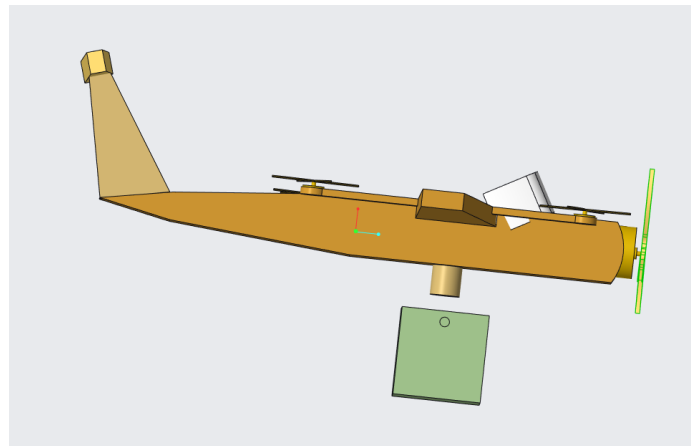

Figure 4: Plan view

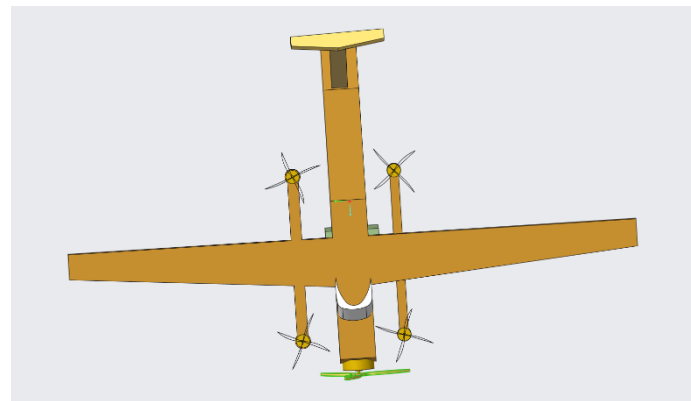

Figure 5: vertical view

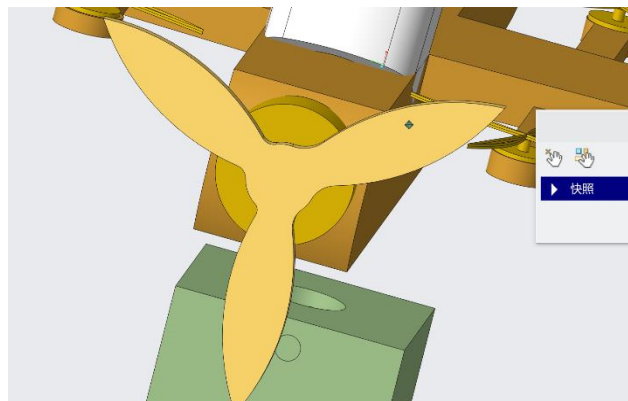

Figure 6: Front blade

This is the propeller at the front of the UAV, which can generate upward lift to overcome the gravity of the helicopter (Fig. 7). You can control the rotor to make it rotate, and still produce a certain lift to slow down the downward trend of the helicopter. It can also generate forward horizontal component force to overcome air resistance and make the helicopter forward.

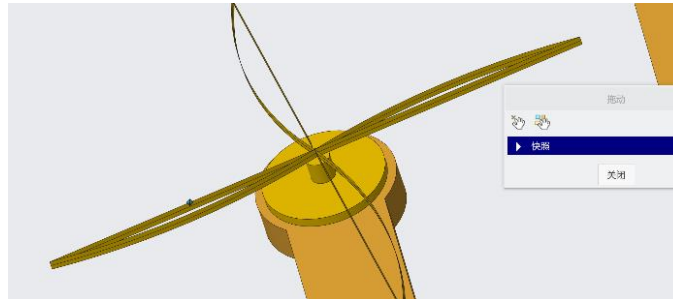

Figure 7: Rotor blade

The propeller is an important part of the UAV power system. The propeller shaft produces a pull force on the UAV to make the UAV move forward and upward. For a propeller, the blade of the propeller has an included angle with the rotation plane, so it will generate thrust on the air when it rotates. Because of the existence of the included angle, we can measure the included angle and measure the pitch. The longer the diameter of the propeller, the greater its pull force at the same motor speed, and the smaller the diameter, the smaller the pull force. Propellers can be divided into positive propeller and reverse propeller. Generally, the front of the propeller is smooth, and the corresponding propeller parameter values will be engraved on the blade. When the propeller is facing forward, it is positive propeller that generates tension when rotating counterclockwise, and it is negative propeller that generates tension when rotating clockwise.

### 3. UAV Function

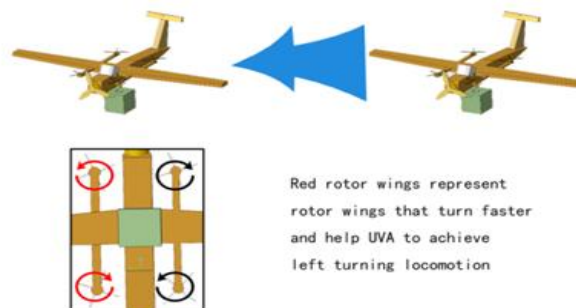

Figure 8: Forward and backward locomotion

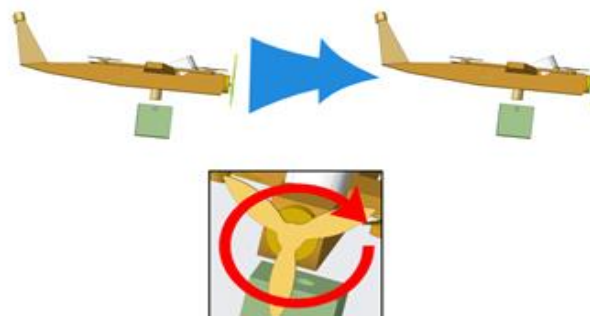

Figure 9: Left and right locomotion

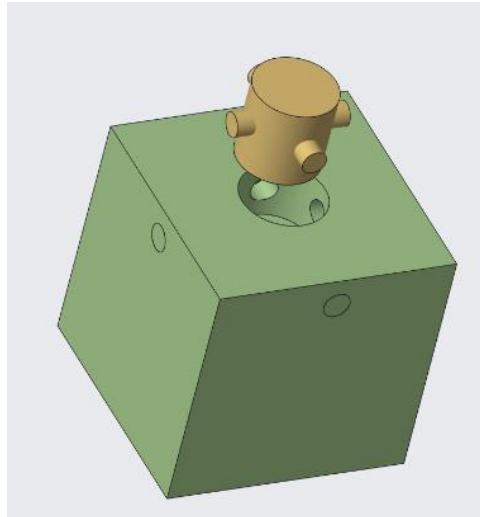

Figure 10: Freight unit

The locomotion of this UAV can be separated into two parts: vertical and horizontal rotation. Firstly, about vertical movement, this UAV uses its four vertical rotor wings in order to change altitude. Additionally, diagonal wings have the same rotational direction, and two groups of diagonal wings have different directions (clockwise and anticlockwise). Secondly, horizontal movement needs both vertical rotor wings and horizontal rotor wings. On the one hand, the left and right movements require different turning speed of rotor wings-- for right translation, two rotor wings on right side should decrease speed and two rotor wings on left side should increase speed, vice versa (Fig. 8). On the other hand, for forward-backward translation, four vertical rotor wings should keep the same rotational speed and horizontal rotor wings increase speed (Fig. 9). Thirdly, clockwise spinning requires clockwise spinning rotor wings increase their speed, and decrease speed of anticlockwise spinning rotor wings. Anticlockwise spinning should force anticlockwise spinning rotor wings to increase rotational speed and reduce clockwise spinning rotor wings rotational speed. This is a device used to fix the express box. This UAV can transport express, so there is a hook at the bottom. The whole hook is cylindrical, there are four retractable small cylinders on the four sides of the big cylinder. Usually these four small cylinders are enclosed inside. The express box is specially made with corresponding opening and card slot (Fig. 10). When transporting, the UAV inserts the large cylinder into the opening of the box and four small cylinders will extend into the card slot, which can well fix the express box and ensure safety during transportation.

This picture shows the whole process of express delivery of our two-in-one UAV (Fig. 11). First, the UAV loads the cargo, then uses the rotor to take off vertically, and then uses the front propeller and fixed wing to accelerate the flight. After arriving at the target site, use the rotor to descend and unload the cargo, and then use the front propeller and fixed wing to quickly return. Finally, return to the starting point and use the rotor to descend.

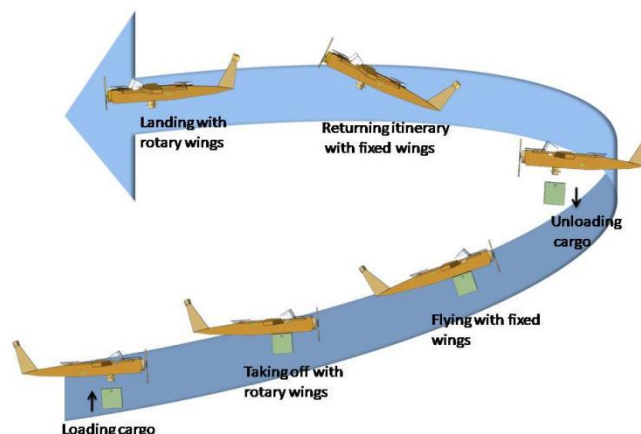

Figure 11: Express delivery process

#### 4. Conclusion

Eventually, we designed this advanced UAV, which can deal with problems of modern UAVs by connecting fixed-wings and rotor-wings' feature together and achieve a balance of mobility and long-lasting ability. Moreover, this novel UAV can deal with cargo delivery issues and bring convenience to the delivery system. More countryside will be available to grab goods as well as urban centers. People will benefit and this is what we are looking forward to.

At present, the UAV designed by us still has high wind resistance and low energy efficiency. We will further improve the appearance and blade structure of our UAV in the future to reduce the wind resistance of the UAV. On the other hand, drones also have safety problems. We will add some physical protection measures to the drones to ensure that safety problems will not occur.

#### References

- [1] Qing Bo, & Wang Lei. (2002). *A review of UAV development. Flying missile*(8), 7.
- [2] He Xiangzhi, Wang Rongchun, & Luo Qianqian. (2010). *Design and simulation verification of longitudinal control law for fixed wing UAV. Science, Technology and Engineering*(9), 5.
- [3] Minnis, P., & Smith, W. L. (1998). *Cloud and radiative fields derived from goes8 during success and the arm-uav spring 1996 flight series. Geophysical Research Letters*, 25(8), 1113-1116.
- [4] Zarco-Tejada, P. J., V González-Dugo, & Berni, J. (2012). *Fluorescence, temperature and narrow-band indices acquired from a uav platform for water stress detection using a micro-hyperspectral imager and a thermal camera. Remote Sensing of Environment*, 117(none), 322-337.
- [5] Darren, T., Arko, L., & Christopher, W. (2012). *An automated technique for generating georectified mosaics from ultra-high resolution unmanned aerial vehicle (uav) imagery, based on structure from motion (sfm) point clouds. Remote Sensing*, 4(5), 1392-1410.
- [6] Niethammer, U., James, M. R., Rothmund, S., Travelletti, J., & Joswig, M. (2012). *Uav-based remote sensing of the super-sauze landslide: evaluation and results. Engineering Geology*, 128(none), 2-11.
- [7] Yue Jilong, Zhang Qingjie, & Zhu Huayong. (2010). *Brief analysis on the research progress and key technologies of micro four-rotor UAV. Electro-optics and control*, 17(10), 7.
- [8] Zhang Jing, Zhang Hua, Liu Heng, & Huo Jianwen. (2014). *Fuzzy PID control of miniature quadrotor UAV. Ordnance automation*, 33(6), 5.
- [9] Ji Jiangtao, Hu Feifei, He Zhitao, Du Xinwu, Liu Jianjun, & Zhu Zhihua, etc. (2013). *Application of four-rotor UAV in farmland information acquisition. Agricultural mechanization research*, 35(2), 4.
- [10] Zhan Lei, He Renqing, Xie Yang, & Long Yan. (2011). *Intelligent navigation system based on miniature quadrotor UAV. Electronic measurement technique*, 34(6), 4.
- [11] Liu Cong, Wei Zhiqiang, Han Hongrong, & Shan Zezhong. (2021). *Aerodynamic response analysis of UAV rotor hover state under crosswind action\*. Chinese Journal of Safety Science*, 31(9), 106-112.
- [12] Guo Naihuan, & Xiong Jingjing. (2022). *Design of neural adaptive sliding mode control for a common axis octorotor UAV. Electro-optics and control*, 29(2), 93-98.
- [13] Chen Dengfeng, Di Jianqin, Zhang Wen, & Liu Guo. (2020). *Dynamics modeling and simulation of tailless flapping wing UAV. Computer measurement and control*, 28(6), 5.
- [14] Zhang Songling, Song Guoxiang, & Wang Fang. (2017). *Bionic flapping wing reconnaissance UAV based on remote monitoring and gps positioning. Electronic world*(11), 2.
- [15] Li Man. (2020). *Hanwang's new technology bionic flapping wing aircraft "The first bird" was unveiled. Scientific and technological innovation and brand*(11), 3.
- [16] Liu Meng. (2019). *Development of piezoelectric two-chip material driving circuit for small flapping wing UAV. (Doctoral dissertation, Jilin University)*.
- [17] Wu Saifei, Wang Xinhua, Jia Sen, Wang Shuo, & Yang Mingchao. (2016). *Automatic landing guidance system of fixed wing UAV based on infrared vision. Electronic measurement technique*(3), 5.
- [18] Beard, R., Kingston, D., Quigley, M., Snyder, D., Christiansen, R., Johnson, W. & Goodrich, M. (2005). *Autonomous vehicle technologies for small fixed-wing UAVs. Journal of Aerospace Computing, Information, and Communication*, 2(1), 92-108.
- [19] Li Jian. (2022). *Vertical takeoff and landing fixed wing UAV. Shaanxi coal*, 41(6), 6.
- [20] Li Yang, Pan Yifeng, & Zhang Jing. (2020). *Application of light and small sar in emergency surveying and mapping based on fixed wing UAV platform. Geology and ore mapping*, 3(5), 83-84.