

Research on DC Electronic Load System Based on BP Neural Network PID Control

Keren He*, Liwei Jiang

School of Microelectronics and Control Engineering, Changzhou University, Changzhou, 213164, China

*Corresponding author

Abstract: DC electronic load is a kind of instrument to replace the traditional dissipative resistance, which is widely used in the discharge performance test of DC power supply. However, it is difficult to achieve better control effect through analog circuit control in some test environments with high speed requirements for discharge test, and it is easy to produce overshoot. In digital circuits, however, in the actual control of DC electronic load, there are many uncertainties in the control system, such as interference and delay, which makes it difficult for the system to achieve the best control effect. This paper takes constant current mode as an example, in order to improve the effect of PID control, BP (Back Propagation) neural network is used to dynamically adjust the PID parameters online. After simulation analysis, under the ideal control environment, the adjustment time of BP-PID is only 0.0002s, which is 0.0005s higher than the traditional PID of 0.0007s. It can also reach a stable value within 0.0003s in the interference environment, with almost no overshoot. Therefore, compared with traditional PID control or analog circuit control, BP neural network PID control has better control effect on DC electronic load system.

Keywords: DC electronic load; PID control; BP neural network; overshoot; interference

1. Introduction

With the gradual development of new energy, the demand for electrical equipment is increasing, and a large number of aging tests are needed when the equipment leaves the factory [1]. The traditional performance test [2] is easily disturbed by temperature and other factors, so it has great limitations. DC electronic load has been widely used because of its small size, easy to carry, high precision, easy to operate, and has become a research hotspot. DC electronic load can be divided into four modes according to different applications: constant current mode, constant voltage mode, constant resistance mode and constant power mode. The constant current mode studied in this paper absorbs the electric energy provided by the power supply with a constant current value, but in the actual control circuit, interference and delay make the system easy to overshoot, so it is difficult to achieve the best control effect. Some scholars [3-6] studied the application of PID control to DC electronic load, which greatly improved the flexibility of control and kept the control accuracy within 0.1%. The key point of PID control is parameter setting, traditional methods such as Ziegler-Nichols method and trial and error method cannot dynamically adjust parameters according to the actual situation, so it is difficult to get a good control effect [7]. With the emergence of intelligent algorithms such as neural network, the digital control of instruments becomes more excellent and flexible. In order to improve the effect of PID control, this paper adopts BP neural network to dynamically adjust PID parameters online [8]. Through simulation analysis, BP neural network PID control has a good control effect on the system, improve the response speed and stability of the system, and reduce the overshoot.

2. DC Electronic Load Model Construction

As shown in Figure 1, the MOSFET has three poles, namely Gate pole, Source pole and Drain pole. When the MOSFET is in the constant current region (also known as the saturation region, amplifying region, and active region), the current almost does not change with the voltage changes at both ends of the drain and source electrodes, showing a constant current characteristic. The DC electronic load power circuit is mainly a closed-loop composed of operational amplifier and MOSFET. The current value is calculated by sampling resistance R_6 , and the given reference voltage is V_{ref} . Because the system of the

circuit has nonlinear characteristics, it is difficult to complete by conventional modeling methods, so MATLAB system identification toolbox is used to obtain the mathematical model of the system. This system is single input and single output, as shown in Figure 2 after importing data.

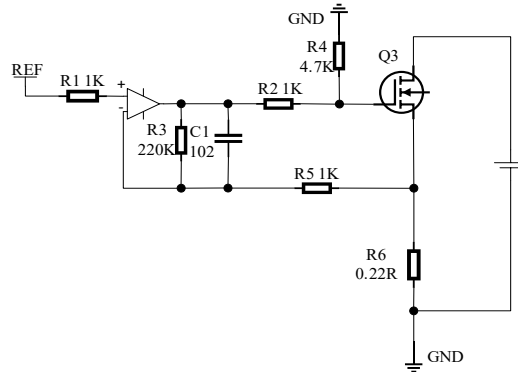

Figure 1: Power circuit model

The curve fitting degree of the output waveform reaches 87.03%, and the obtained transfer function meets the requirements of system identification. Therefore, the approximate transfer function of DC electronic load system can be obtained by MATLAB system identification tool as follows:

$$G(s) = \frac{537}{s + 27.5} \quad (1)$$

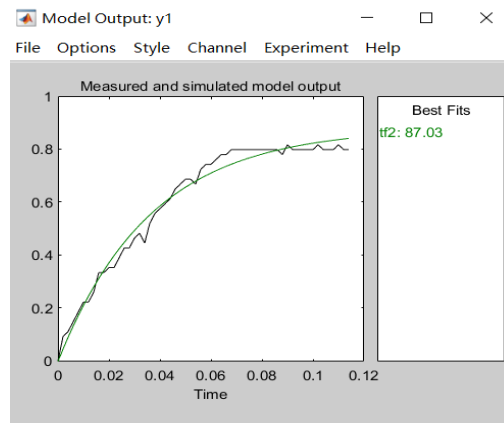

Figure 2: Fitting curve

3. The control method of Dc electronic load

3.1. PID control

Traditional PID control is widely used in industrial control and is a mature control method^[9]. The algorithm expression is as follows:

$$u(t) = K_p(e(t) + \frac{1}{T_i} \int_0^t e(t)dt + T_d \frac{de(t)}{dt}) \quad (2)$$

Where, K_p is the proportion coefficient, T_i is the integration time constant, T_d is the differential time constant; $u(t)$ is the output of the controller, and $e(t)$ is the error value of the last two controller outputs.

Because the computer is a kind of sampling control, the control quantity can only be calculated according to the deviation value of sampling time. Therefore, the continuous PID control algorithm can not be directly used, this paper adopts incremental PID control, its formula is:

$$\begin{cases} \Delta u(k) = K_p(e(k) - e(k-1)) + K_i e(k) + K_D(e(k) + e(k-2) - 2e(k-1)) \\ u(k) = u(k-1) + \Delta u(k) \end{cases} \quad (3)$$

3.2 BP neural network PID control

BP neural network is an intelligent algorithm, which can approximate any nonlinear function. Although PID is the most commonly used control mode, it is not suitable for complex nonlinear environment control, so the learning ability of neural network can give full play to the control effect of PID. There are two methods for weight correction of BP neural network: online method and offline method [10]. In this paper, the online method is used for weight update, so there is no need to generate data sets in advance. The structure of neural network is composed of input layer, hidden layer and output layer, and the number of neurons in each layer is 4, 5 and 3 respectively. The model is shown in Figure 3.

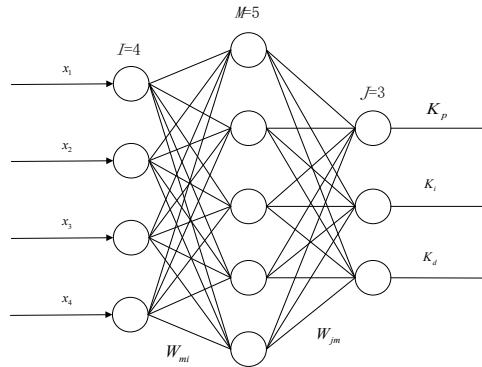

Figure 3: Structure diagram of BP neural network

The activation function of hidden layer adopts bipolar S-function:

$$f(x) = \tanh(x) = \frac{e^x - e^{-x}}{e^x + e^{-x}} \quad (4)$$

The activation function of the output layer adopts the unipolar S-function:

$$g(x) = \frac{1}{2}(f(x) + 1) = \frac{e^x}{e^x + e^{-x}} \quad (5)$$

The performance index function of neural network is:

$$E(k) = \frac{1}{2}[r(k) - y(k)]^2 \quad (6)$$

BP neural network PID control algorithm flow is as follows [11]:

- 1) Determine the network structure, initialize the weight system of each layer, and determine the learning factor and inertia factor.
- 2) Calculate the input and output of each layer of the neural network, and finally calculate, K_p , K_i , K_d
- 3) Calculate the output $u(k)$ of PID controller.
- 4) Calculation error $e(k) = r(k) - y(k)$
- 5) online adjustment of the weight coefficient, the realization of PID control adaptive adjustment
- 6) Set $k = k + 1$ and return to Step 2

3.3 System structure

The digital control structure of DC electronic load is shown in Figure 4. In constant current mode, given a reference voltage $r(k)$, the AD sensor transmits the voltage of the current sampling resistance to the microcomputer, and then the microcomputer transmits three parameters such as the calculated voltage difference after sampling to the neural network PID controller. Then the PID controller output data through the DA sensor output voltage control MOSFET opening and closing. The four input values of BP neural network are the reference voltage $r(k)$, the actual on-board current $y(k)$, the difference between the target value and the actual value $e(k)$, and the difference between two deviations $\Delta e(k)$, which is the

speed of error change. BP neural network learns the weight by calculating the error and dynamically adjusts the three parameters of PID controller, so that the whole system approximates the optimal state.

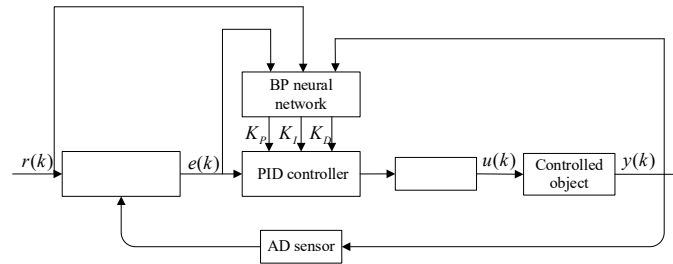

Figure 4: Schematic diagram of PID parameter optimization system

4. Experiment part

4.1 Condition set

In order to verify the control effect of traditional PID and BP neural network PID in the ideal environment and the environment with interference, Matlab is used to conduct simulation experiments on the two situations. Assuming that the output voltage of DA sensor is 0~5V, the output range of PID output $u(k)$ is limited to [0,5]. The three parameters of traditional PID are set as $K_p=100$, $K_i=1$, $K_d=0.1$, and the sampling time is set as 10us. In the BP neural network, the neural network has three layers, in which the input layer has four input parameters, namely $r(k)$, $y(k)$, $e(k)$, $\Delta e(k)$, and the weight coefficient between each neuron is a random number between [-1,1]. The simulation sampling period was set as 10us, the learning factor $\eta=0.1$, the inertia factor $\alpha=0.1$.

4.2 Results analysis

It can be seen from Figure 5 that when the target current is set to 1A, for BP neural network PID control and conventional PID control, BP neural network PID control has a faster response speed, reaching the target value in 0.0002s, while conventional PID reaches the target value in 0.0007s. It can be seen that BP-PID is better than conventional PID in regulating time. However, there are many uncertain factors in the actual control environment, so the difference between the two control methods is not obvious from the ideal environment.

In order to simulate the actual test environment, this experiment adds interference before 0.001s. In the environment with interference, as shown in Figure 6, the BP neural network PID control basically reaches the steady-state value at 0.0003s, and the overshoot is small and can be basically ignored. However, the traditional PID has a large overshoot and only reaches the steady state value at 0.0005s. Therefore, in the environment of interference, BP-PID control is better than the traditional PID control.

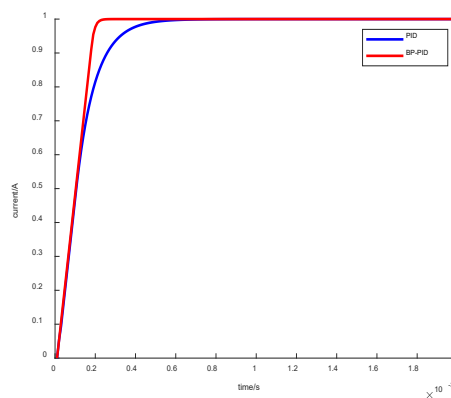

Figure 5: Ideal environment

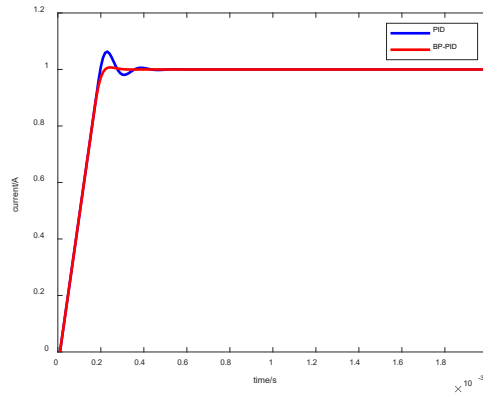

Figure 6: Interference environment

From simulation results such as Table 1 and Table 2, the BP neural network PID control effect is superior to the traditional PID control both in the ideal environment and in the interference environment, therefore the BP neural network PID control can make DC electronic load system in good working condition, and with the change of the environment can make corresponding adjustment.

Table 1: Simulation results under ideal environment

Control method	overshoot/%	Response time/s
PID	0	0.0007
BP-PID	0	0.0002

Table 2: Simulation results in jamming environment

Control method	overshoot /%	Response time /s
PID	6.3	0.0005
BP-PID	0.5	0.0003

5. Conclusion

Due to the development of new energy industry, DC electronic load has been widely used, and the test requirements for DC electronic load are gradually increasing. During operation, stability is an important index of DC electronic load, but due to system interference or delay, the instrument is prone to overshoot. At the same time, in the digital circuit, the traditional PID control can not achieve a good control effect in the nonlinear time-varying system, so aiming at this problem, this paper designs a DC electronic load control system based on BP neural network PID control, through the BP neural network real-time adjustment of PID parameters. The DC electronic load has high stability in battery discharge test. The simulation results show that the BP neural network PID control is better than the traditional PID control for the DC electronic load system. In the future, further research will focus on higher speed control and apply the algorithm to actual products to constantly adapt to the needs of the industry.

References

- [1] Liu, W., Zhu, C., and Gu, Z. (2020). *Development and Key Technologies of Electronic Load for Mobile Power Station Testing* [J]. *Foreign Electronic Measurement Technology*, 2020, 39(01):131-137.
- [2] An, J., Liu, X. (2021). *Study on Regenerative AC Electronic Load for Power Supply Test* [J]. *Advanced Technology of Electrical Engineering and Energy*, 2021, 40(08):66-72.
- [3] Liang, J., Mu, P. (2018). *Design of DC Electronic Load Based on STM32* [J]. *Electronic Measurement Technology*, 2018, 41(22):116-120.
- [4] Hu, G., Ma, X., Yan, W., et al. (2015). *Research on a High Precision Constant Current Source DC Electronic Load* [J]. *Measurement and Control Technology*, 2015, 34(01):107-110.
- [5] Zhang, W., Yao, T., Zhao, J., et al. (2015). *DC Electronic Load Device Based on MSP430 Microcontroller* [J]. *Laboratory Research and Exploration*, 2015, 34(08):77-80.
- [6] He, S., Kong, F., and Yang, L. (2012). *Application of Fuzzy Neural PID Control Based on Improved PSO* [J]. *Automation and Instrumentation*, 2012, 27(04):35-39.
- [7] Meng, J., Chen, Q., and Zhang, K. (2013). *Simulation of PID Control for Vehicle Suspension Based*

on PSO Algorithm [J]. *Computer Simulation*, 2013, 30(04):155-158+168.

[8] Xu, J., Zhang, M., Wang, Y., et al. (2015). Energy Storage Capacitor Constant Current Charging Control System Based on BP Neural PID [J]. *Control Engineering of China*, 2021, 28(05):851-855.

[9] Tian, Y., Xu, Y., Ren, K., et al. (2020). Adaptive Control Method of the Electroslag Furnace Based on Particle Swarm Optimization [J]. *Control Engineering of China*, 2020, 27(06):1043-1048.

[10] Qiu, Z., Li, S. (2018). Modeling and Simulation of Networked Control Systems Based on Neural Network [J]. *Journal of System Simulation*, 2018, 30(04):1423-1432.

[11] Zhang, L., Li, J. (2018). Liquid Level Controlling of Multi-effect Evaporation Processes Based on BPNN-based PID [J]. *Instrument Technique and Sensor*, 2018(03):98-101+107.